

# An integrated simulation-based method for considering weather effects on concrete work tasks' productivity and concrete curing

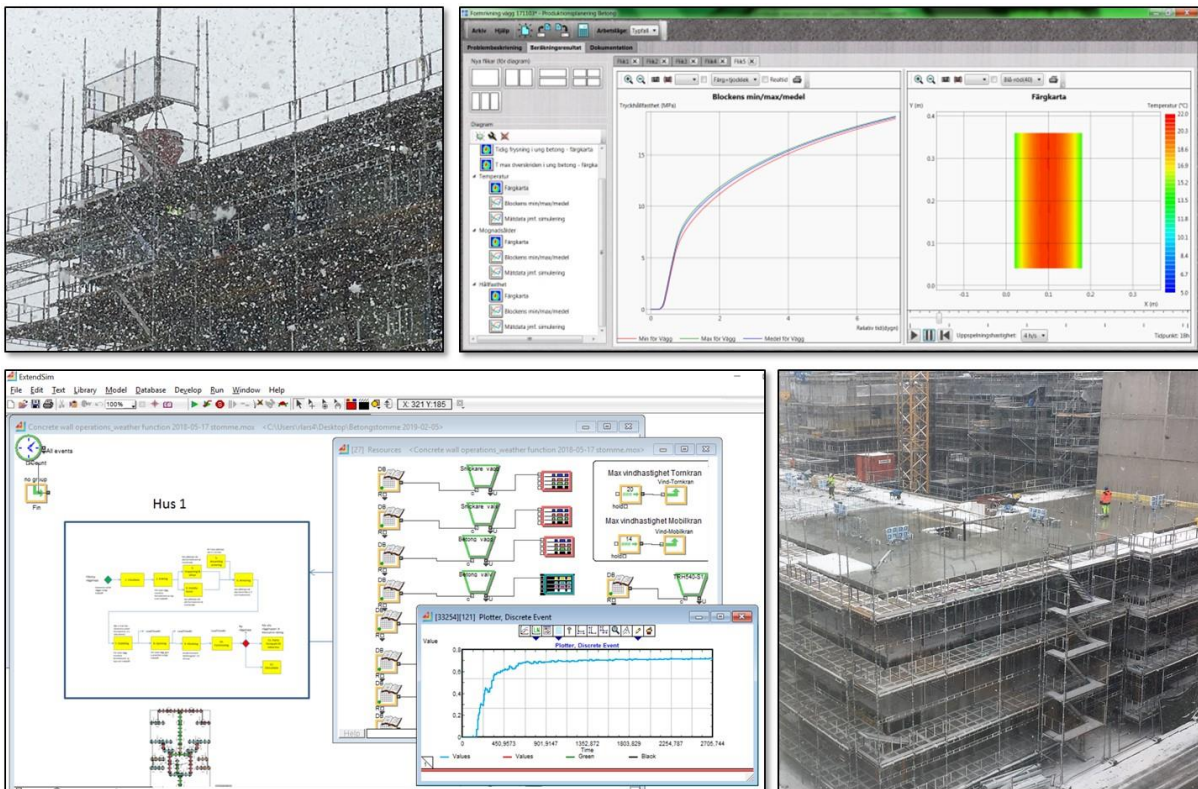

Robert Larsson, Lund University



**LUND**  
UNIVERSITY

Report TVBK-3075

ISBN 978-91-87993-17-6

Lunds tekniska högskola

Avdelningen för konstruktionsteknik

Box 118

221 00 LUND

## Preface

This report presents an integrated simulation-based approach to study the on-site production of concrete frameworks by considering the multiple effects of weather on work task productivity and concrete curing process. The suggested approach enable to systematically study how different weather conditions and the use of climate-improved concrete in combination with different methods to shield concrete curing, affect construction time, cost, and carbon emissions.

Concrete construction productivity is affected by weather in at least three ways; 1) manual and machine-assisted work tasks are either hindered or the working pace are reduced; 2) curing of concrete may be subjected to early freezing or may lead to delayed formwork removal; 3) measures to shield concrete curing against weather may imply for additional work tasks and need for extra resources affecting the overall productivity. The results presented in this report indicate that these effects (1-3) collectively extend construction time by 8-42% due to various weather conditions depending on season and location of project. The results also highlight potential reductions in carbon footprint of concrete frameworks by employing climate-improved concrete. However, weather conditions become even more important to consider when using these concrete types since they are generally more sensitive to certain weather conditions, e.g. cold temperature in combination with windy conditions.

This report is a result of a research project carried out at Lund University, div. of Structural Engineering. I would like to thank my supervisor Prof. Martin Rudberg (Linköping University), my assistant supervisors Ronny Andersson (Cementa AB) and Miklós Molnár (Lund University) for insightful and valuable comments on this report. The research project has been financially supported by the Swedish construction industry's organization for research and development (SBUF) and Cementa AB. Several concrete manufacturers and contractor companies are also kindly acknowledged for their involvement and collaboration during this research project. The author would also thank Jonas Enhörning at Duke Systems AB for technical support related to ExtendSim.

Robert Larsson, Phd Student

Lund University, Div. Structural Engineering

## Table of content

<b>1. Introduction</b> .....	6
<b>2. Research approach</b> .....	8
<b>3. Weather-related effects on concrete construction productivity</b> .....	9
3.1 Effects on work task productivity .....	10
3.1.1 Temperature .....	10
3.1.2 Precipitation .....	10
3.1.3 Wind speed .....	11
3.1.4 Summary of effects on work task productivity .....	11
3.2 Effects on work task productivity .....	11
3.3 Methods for shielding concrete curing in cold weather .....	13
3.4 Simulation of concrete temperature and strength development .....	14
<b>4. Field studies</b> .....	15
4.1 General description of field studies and data collection .....	15
4.2 Field study A - Documentation of on-site construction process .....	16
4.3 Field study B - On-site measurements of concrete temperatures .....	17
4.3.1 Description of on-site measurements .....	17
4.3.2 Comparison of simulated and measured temperatures .....	19
<b>5. Weather data analysis</b> .....	21
<b>6. Simulation of formwork removal times</b> .....	22
6.1 Introduction .....	22
6.2 General prerequisites for simulation .....	22
6.3 Concrete mixtures .....	24
6.4 Concrete curing strategies .....	24
6.5 Formwork removal times .....	25
<b>7. Discrete-event simulation model</b> .....	26
7.1 General description .....	26
7.2 Algorithm for considering effects of weather on work task productivity .....	27
7.3 Algorithm for considering effects of weather on formwork removal times .....	28
7.4 Calculation of time buffers during concrete curing .....	30
7.5 Cost data .....	31
7.6 Carbon emission data .....	32
7.7 Validation of model inputs and logical behavior .....	33
<b>8. Design of simulation experiments</b> .....	34
<b>9. Results</b> .....	35
9.1 Normal weather conditions .....	35
9.2 Unusual weather conditions .....	39

9.3 Selection of optimal strategy .....	40
<b>10. Discussion and conclusions .....</b>	<b>41</b>
10.1 Model for considering effects of weather on both work tasks and concrete curing.....	41
10.2 Implications of climate-improved concrete and need for curing methods .....	41
10.3 Research limitations and need for further research .....	43
10.4 Conclusions.....	44
<b>References .....</b>	<b>45</b>
<b>Appendix .....</b>	<b>48</b>

## 1. Introduction

Reinforced in-situ concrete is widely used as a structural material in frameworks of multi-story buildings. In-situ concrete provides important stability, fire safety, and durability to the structural framework. However, in an improvement perspective the construction method is still labour-intensive, involves manual activities carried out in unprotected environments exposed to varying weather conditions (Illingworth 2000; Moselhi et al. 1997). Accordingly, weather is an important factor during the construction phase as it influences the ability to perform work effectively. Hot and cold temperatures, rain or snowfall reduce labour productivity. High winds may also reduce productivity since work that involves lifting of large objects cannot be executed for safety reasons.

In addition, weather conditions also influence the development of concrete strength typically denoted as the concrete curing process (Bagheri-Zadeh et al. 2007). For example cold temperatures and high winds slow down the rate of the curing process. Such a slower curing process means that the formwork may not be possible to remove as planned since actual concrete strength has not met the minimum strength requirements for formwork removal. Delayed formwork removal has in most situations where production is time critical, a significant influence on construction duration since succeeding work is dependent on freeing the formwork in order to reuse panels at other work areas. Accordingly, any delays in when formwork can be removed directly impose further delays, extending the construction duration. Corrective measures in order to make up for such delays are typically difficult and costly to employ.

The influence of weather on concrete curing may become even more important as the interest of using climate-improved concrete is growing. In addition, the positive implication of reduced carbon emissions by avoiding the use of higher concrete quality than required for structural or durability reasons, have also contributed to the need for extended knowledge about how different weather conditions influence concrete curing. Reducing the climate impact of concrete usually means to partially substitute Portland cement clinker in the concrete mixture, e.g. by using blended cement types and/or by adding supplementary cementitious materials (SCMs) separately in the concrete mixer. Examples of SCMs are fly ash and blast-furnace slag. However, using SCMs in concrete mixtures may delay formwork removal since these concrete types have typically a slower concrete strength development at lowered temperatures (Lothenbach et al. 2011). In addition, the release of internal heat from the chemical hydration process is also lower, which means that these concrete types become more sensitive to early freezing caused by cold temperatures. As a result, more extensive measures are needed in order to protect the fresh concrete from cooling. Therefore, this study focuses on in-situ concrete production methods applied to projects governed by construction cost, time and climate impact and where on-site production works are exposed to cold weather representative for Scandinavian conditions.

It is obvious that planning of construction projects involving use of in-situ concrete production methods, must consider the effect of varying weather conditions, especially when employing climate-improved concrete types. Unfortunately, traditional tools used for planning construction work flow are not capable to fully consider the various effects of weather on labour productivity and material-related process, e.g. concrete curing. When it comes to the effects on work task productivity, several studies have been conducted within construction management

research. The research studies have mainly focused on estimating the influence of different weather factors on single (or group of) work task productivity (e.g. [Koehn and Brown 1985](#); [Thomas and Yiakoumis 1987](#); [Moselhi and Khan 2010](#); [Jung et al. 2016](#)).

The negative effects of low temperatures, as well as high temperatures, on concrete curing are well known and thoroughly studied in numerous research projects. Today, special-purpose simulation tools also exist to support analysis of temperature and strength development for different concrete mixes and climate conditions. Even though these tools are useful to facilitate choice of concrete types, curing measures for specific weather conditions, they do not include weather effects on the overall construction cycle. Accordingly, these tools do not facilitate a holistic analysis of the concrete production system.

Although it is well known that weather affects both manual work and material-related processes, there are no examples where attempts have been made to describe the impact of weather on both work and material-related processes in an integrated way. Construction management research focus mainly on how weather affects manual work processes, while material researchers have focused on how weather affects individual materials, such as concrete curing.

Therefore, this report aims to describe a model integrating knowledge from both construction management research and material science. The model uses discrete-event simulation (DES) as the platform in where work processes and the effect of weather can be described in a detailed way. DES was chosen since the methodology is suitable to describe complex relationships and dynamic behaviours which typically are present in construction projects where site conditions and weather conditions are changing on hourly basis ([Lucko et al. 2008](#)). Special-purpose simulation software for estimation of concrete strength development was used separately to feed the model with specific data describing formwork removal times for different concrete types, curing measures and weather conditions. Detailed weather statistics are used to consider the effects of varying weather due to geographical locations, seasonal effects, and different climate conditions. The model is capable to simulate the working process of erection of in-situ concrete frameworks and explicitly consider the effects of weather on manual working processes and concrete curing processes. The total effect of different weather conditions can be studied systematically in a highly controlled environment. The model reports simulated construction time, cost, and CO<sub>2</sub> emissions for a specific construction setup. This facilitates planning and decisions related to resource allocation strategies, construction schedules, different concrete types (including climate-improved concrete), and curing measures for different types of expected weather conditions.

The research questions (RQ:s) formulated as a basis for this report were;

*RQ1: How can DES be used in order to study the effect of weather on in-situ concrete construction considering both manual work processes and material-related processes?*

*RQ2: How is concrete framework construction affected by varying weather conditions when climate-improved concrete types are used in combination with different curing measures?*

Research question 1 was formulated to address the methodological and technical aspects of integrating existing knowledge regarding the influence of weather on work task productivity as well as on concrete curing and how these two types of effects can be described into a discrete-event simulation model. This is necessary in order to develop models to enhance the prediction

of how weather affects construction projects. To the authors' knowledge, this has not been addressed in previous research. Research question 2 addresses the implications of concrete construction exposed to varying weather conditions particularly considering the use of climate improved concrete types and different curing measures. This is motivated by the general interest in quantifying the effects of weather to make construction projects more adopted to different weather conditions, but also to respond to the growing need for using concrete types with reduced carbon emissions.

The report is organized in the following way. In section two, a description of the research methodology is presented. The next section deals with the effects of weather on construction works in general and concrete as material in particular. The field studies used for process documentation, data collection, and in-situ measurements of concrete temperatures are described in section four. In section five, analysis of weather statistics are described followed by a section describing how formwork removal times have been determined. The discrete-event simulation model is presented in section seven followed by a description of the simulation experiments conducted. Finally, results are presented in section nine followed by a section in where implications of the results are discussed.

## 2. Research approach

The research approach is outlined in figure 1. The process consisted of seven steps which were carried out both sequentially and in parallel. At some stages, the process was also iteratively executed even though such loopbacks are not formally represented in figure 1. A literature review was conducted as a start (step 1). At this stage, a review of previous research related to weather effects on construction works and concrete curing was conducted. In addition, available tools for prediction of concrete strength as well as sensor systems for real-time in-situ measurements were reviewed. The review also involved literature covering cost of concrete structures as well as climate impact. The purpose of step 1 was to gain knowledge needed to perform field studies (step 2), collect and analyse weather data statistics (step 3), and to collect, structure, and analyse cost and climate data for concrete framework construction (step 5).

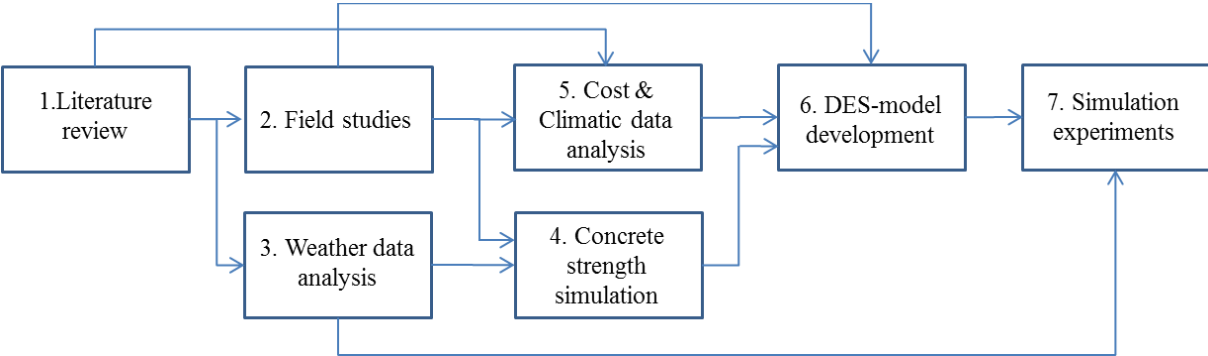

Fig. 1. Outline of the research process.

The field studies (step 2) consisted of two separate projects which were similar regarding building type and construction method. In the first field project (field study A), the construction process was documented. It also involved to obtain practical knowledge regarding how weather



influences production and what operational measures that are usually employed to protect concrete curing against ambient climate. In the second project (field study B), concrete temperatures were measured using a sensor system. The measured temperature data was later used to validate the special-purpose simulation tool for prediction of concrete formwork removal time (step 4).

In step 3, weather data covering different weather factors were collected for three geographical Swedish locations. The weather data was used in step 4 to set boundaries for external weather conditions when simulating formwork removal times. The same weather data was also used in step 7 in order to feed the simulation model with different climate scenarios. In step 4, formwork removal times for different concrete types, curing measures and climate conditions were simulated using a special-purpose simulation tool. At this stage, simulated temperatures were compared with measurements conducted in field study B. Simulated formwork removal times for different concrete types, curing measures and climate conditions were then structured and prepared to be integrated into the discrete-event simulation model.

In step 5, costs and climate data for concrete framework construction were collected from multiple sources, structured, and analysed. Cost data were retrieved from reports where construction costs have been followed-up and analysed. Some cost items have also been collected from contractors, suppliers of concrete, formwork, and equipment involved in the field studies. In addition, price lists of materials and equipment have also been reviewed. Accordingly, cost data were validated by collecting data for the same type of item from different sources and then comparing them. The climate impact of concrete framework construction was limited to CO<sub>2</sub> emissions from concrete mixtures including sourcing of raw materials (e.g. cement, aggregates etc) and production of concrete at factory plants. Data on carbon emissions were retrieved from environmental product declarations (EPD). EPD:s are third party certified declarations standardized in Europe by EN15804 and globally by ISO 14025, and are based on attributional LCA. In addition, also CO<sub>2</sub> emissions from concrete curing measures taken place on-site were calculated. Cost data together with CO<sub>2</sub> emissions were finally structured and prepared to be integrated into the simulation model framework.

Based on all previous steps, development of the simulation model was conducted in step 6. A general-purpose discrete-event simulation tool was used as the platform. The on-site construction process observed and documented in field study A, were modelled together with functions to describe resource usage and the influence of weather. Special algorithms were also developed to consider the effects of weather on formwork removal. The model was validated against the construction process observed in field study A. The model itself was the main contribution for answering RQ1. In the final step, theoretical experiments were conducted using the developed simulation model. Finally, the simulation results were compiled and analysed which then were used to answer RQ2.

### 3. Weather-related effects on concrete construction productivity

Most concrete construction works are, as many other types of construction methods, carried out at unprotected working areas and therefore exposed to varying weather conditions. Accordingly, labour workers, machinery and material are influenced by current weather conditions but in different ways. For instance, adverse weather slows down working pace among labour, weather-sensitive materials have to be protected, and machinery cannot be

operated as usual. All these show on examples of different consequences due to adverse weather but the ultimate effect is typically a loss in construction productivity. In this chapter, the influence of weather on productivity is divided into effects on manual work tasks including machinery assisted work tasks and effects on concrete curing as it is critical to keep-up productivity in concrete work cycles.

### 3.1 Effects on work task productivity

The effects of weather on work task productivity have been a research topic for many years within the scientific field of construction management. In general, research studies have pointed out temperature, precipitation, and wind speed as the most important weather factors influencing work task productivity (Larsson and Rudberg 2019).

#### 3.1.1 Temperature

Labour productivity is negatively affected both at cold and hot temperatures. Physiologically, hot temperatures may lead to heat stress or dehydration among humans. At cold temperatures, workers may experience general body cooling or tissue damages (Holmér 1994) and reduced finger and hand dexterity (Mäkinen et al. 2005). The cooling effect of wind speed and low temperature in combination also increases the risk of health effects, and air humidity affects productivity both at high and low temperatures.

The relationship between work productivity and temperature has been studied in several research projects, e.g. Koehn and Brown (1985), Thomas and Yiakoumis (1987), Hassi (2002), Thomas and Ellis (2009), and Moselhi and Khan (2010). In general, these studies concluded that temperatures in the range between 10 and 25 °C had no effect on productivity. However, both colder and warmer temperatures led to significant reductions, although the magnitude of the reduction values differs between the studies.

#### 3.1.2 Precipitation

Rain and snow typically reduce productivity since workers have to spend time on actions to cover materials and work areas. Precipitation in combination with cold temperatures can also cause slip-and-fall accidents (Jung et al. 2016). Moreover, a snowfall on an unprotected work area requires additional time for shoveling and cleaning. Previous research has reported that labour productivity is negatively affected by precipitation even at light or moderate intensity. For instance, Moselhi and Khan (2010) report that light rain or snow result in a productivity loss by 40%. Other studies e.g. reported by Noreng (2005) conclude that light rainfall (0.3 mm/h) causes a productivity loss by 65%. Thomas and Ellis (2009) reported similar effects due to rain and snow even though the intensity of precipitation was not explicitly determined. If the intensity of a rain or snowfall becomes too high, the work may have to stop leading to a loss in productivity equal to 100%. Jung et al. (2016) state that precipitation is the weather factor that causes most work stoppages. However, different types of work tasks are more sensitive to precipitation than others. For instance, Birgisson (2009) argues that construction works on a horizontal surface are more sensitive to precipitation compared with a vertical surface. Some studies have defined threshold values for when certain type of work is affected by precipitation, e.g. Ballesteros-Perez et al. (2015).

### 3.1.3 Wind speed

Wind influence manual work tasks in general but most obviously, it affects work tasks that involve lifting of objects. Typically, high winds hamper the ability to perform any kind of lifting operation in a safe and effective way. The effect of wind on lifting operations depends on a combination of factors, such as wind speed, height of lifting operation, ambient terrain, and type of objects to be lifted. For instance, lifting operations of large light-weight formwork panels are more affected by wind compared with lifting heavy rebar bundles. Wind also affects workers at higher altitudes where strong gusts of wind increase the risk of accidents and may require additional safety measures. The quantitative effects of wind have been reported to be in the range of 17-25% for wind speeds between 8-12 m/s (Noreng 2005; Birgisson 2009; and Moselhi and Khan 2010). Another way of expressing the influence of wind is to determine when wind starts to affect a specific lifting operation (lower limit) and when lifting is cancelled (upper limit). Ballesteros-Perez et al. (2015), report a lower limit for lifting of formwork panels is around 5 m/s. Jung et al. (2016), reports an upper limit of 10 m/s for cancelling lifting of curtain wall elements and pouring concrete using crane and skip. Upper limits may also be stated by national industry regulations or recommendations. Also crane manufacturers provide general recommendations for maximum allowable wind speeds at which crane usage is not allowed. According to international crane manufacturers, in-service wind speeds are, in general, up to 20 m/s for modern tower cranes (Watson 2004). Corresponding wind speeds for mobile crane are up to 14 m/s. However, these recommendations may vary between countries and manufacturers.

### 3.1.4 Summary of effects on work task productivity

Temperature, precipitation and wind all influence work task productivity. Several research studies have estimated the effect of individual weather factors on labour productivity. In general, the effect of weather factors can be described either as continuous numerical values or intervals (e.g. 25% or 20-40% lower productivity), or as a discrete threshold value defining stop condition at where a specific work task is cancelled. It could also be a combination of both continuous values and an upper limit defined by a discrete value. A recent review and summary of weather effects on work task productivity can be found in Larsson and Rudberg (2019). Here, numerical estimations of individual weather factors and their effects on work task productivity are presented. These numerical estimations are also incorporated into the discrete-event simulation model which is further discussed in section 7.2

## 3.2 Effects on concrete curing process

The development of concrete strength is usually described as the hardening or curing process. This material-related process is crucial since it determines several critical aspects of a concrete structure both at early and later stages. For instance, early strength growth of concrete is important to enable for an efficient and safe removal of formwork.

Concrete gains strength due to of the exothermic chemical reactions between the water and cementitious materials in the mixture. Provided that sufficient moisture is present, the rate of the chemical reactions depends on several factors where concrete temperature is important, especially at early age (Fjellström 2013). An increase in temperature increase the rate of reactions and by that also the rate of concrete strength development. Similarly, a decrease in concrete temperature slows down the rate of reactions and the strength growth. However, the influence of temperature is more complex since it has also been confirmed that high

temperatures at early age may reduce the long-term strength (Carino and Lew 2001). Since the concrete temperature is essential for strength growth, the ambient climate conditions become important as they strongly influence the concrete temperature. For instance, cold temperatures and high winds reduce the concrete temperature which in turn slows down or even stops the hydration process.

Early strength development can be estimated using the maturity method (Benaicha et al. 2016; American Concrete Institute 2019). The method is based on scientific findings that the concrete strength can be estimated by considering the relationship between temperature and time on strength development. A maturity index is used to quantify the combined effects of time and temperature. The index is determined by knowing the concrete temperature history and a maturity function. There exist several maturity functions where two are commonly used. The first function is commonly known as the Nurse-Saul function (Nurse 1949; Saul 1951). This function assume that the initial rate of strength growth is a linear function of temperature. The maturity index at a given age is determined by the area between a datum temperature  $T_0$  and the concrete temperature curve according to equation 1. The datum temperature is defined as the lowest temperature at where concrete gains no strength, which has typically been set to  $-10^{\circ}\text{C}$ . However, a more accurate approach would be to evaluate the datum temperature for the specific cementitious materials and admixtures used in the concrete mixture.

$$M(t) = \sum(T_a - T_0)\Delta t \quad (1)$$

Where  $M(t)$  is the temperature-time factor at age  $t$  expressed as deg-days or deg-hours,  $\Delta t$  = time interval (days or hours),  $T_0$  = datum temperature ( $^{\circ}\text{C}$ ),  $T_a$  = mean concrete temperature during time interval  $\Delta t$  ( $^{\circ}\text{C}$ ).

The second maturity function assumes that concrete gain strength exponentially with temperature in accordance with the Arrhenius function (Freiesleben Hansen and Pedersen 1977). Here, the maturity function assumed to determine an equivalent age of concrete at a specified curing temperature. Equation 2 provides the mathematical expression for determining the equivalent age.

$$t_e = \sum e^{-Q\left(\frac{1}{T_a} - \frac{1}{T_s}\right)} \Delta t \quad (2)$$

where  $t_e$  = equivalent age at a specified temperature  $T_s$  (days or hours);  $Q$  = apparent activation energy divided by the gas constant (kelvin);  $T_a$  = mean concrete temperature during time interval  $\Delta t$  ( $^{\circ}\text{C}$ ),  $T_s$  = specified curing temperature ( $^{\circ}\text{C}$ ),  $\Delta t$  = time interval (days or hours). The equivalent age function as given by equation 2, converts a time interval ( $\Delta t$ ) at the actual concrete temperature to an equivalent interval in terms of strength growth at a specified curing temperature. The specified curing temperature,  $T_s$ , is typically set to  $23^{\circ}\text{C}$  in North America whereas in Europe, it is usually set to  $20^{\circ}\text{C}$ . The  $Q$ -value depends primarily on the types of cementitious materials used in the concrete mixture, and to a lesser extent, on the water-cementitious materials ratio.

The equivalent age method is common in the Scandinavian countries (Fjellström 2013) and the mathematical expression is usually described according to equation 3. Note that this expression is similar to equation 2.

$$t_e(T_r) = \int_0^t \exp \left[ \frac{E}{R} \left( \frac{1}{273+T_r} - \frac{1}{273+T_c} \right) \right] * dt \quad (3)$$

where  $t_e$  equivalent curing age (h);  $E$  = activation energy (J/mol);  $R$  = universal gas constant (8.3144 J/mol/K);  $T_r$  = reference temperature (°C); and  $T_c$  = average concrete temperature. The reference temperature is typically set to 20°C. Since the activation energy  $E$  is not always constant, an empirical expression according to equation 4 was suggested by Jonasson (1985) as a more suitable approximation.

$$\theta = \frac{E}{R} = \theta_{ref} \left( \frac{30}{T_c+10} \right)^{\kappa_3} \quad (4)$$

where  $\theta$ (K) is denoted as the activation temperature;  $\theta_{ref}$  and  $\kappa_3$  are maturity parameters determined based on measured concrete strength.

When the equivalent curing age of a concrete is known it can be related to strength by knowing the strength-maturity relationship for a specific concrete mix. This relationship is determined by testing the compression strength at different ages of concrete specimens (cube or cylinder) cured at 20°C. In Sweden, the strength-maturity relationship for a concrete mixture is commonly referred as the “tendency curve”. The function for describing the tendency curve can be found in Fjellström (2013).

As mentioned earlier, knowing the concrete compressive strength at any point in time is crucial in order to ensure a safe formwork removal and quality of end-product. Considering formwork removal, different requirements apply to vertical formwork (e.g. wall form panels) and horizontal formwork such as table forms. When removing vertical formwork, the concrete compressive strength should be at least 6 MPa in order to avoid overturning due to wind loads (Ljungkrantz *et al.* 1992). Removing horizontal formwork, the concrete strength should be at least 70% of the ultimate compressive strength. Another important criteria is to ensure that the concrete strength is at least 5 MPa before internal concrete temperature falls below 0°C (freezing criteria). Early freezing when concrete strength is low may cause a permanent damage and significant loss in final strength (Bagheri-Zadeh *et al.* 2007).

### 3.3 Methods for shielding concrete curing in cold weather

Due to the important influence of cold weather conditions on the curing process, it is usually necessary to employ different types of measures in order to protect concrete against weather. Different types of measures are either used separately or in combination (Cementa 2014).

- a) *Concrete mixture*: An important way to influence the strength growth is to change the constituent materials in the concrete mixture. For instance, lowering the w/c ratio has a positive impact on strength development due to higher cement content. Also, the cement type and/or chemical admixtures influence the rate of strength development.

- b) *Heated concrete*: Increasing the temperature of the concrete mixture delivered to construction site is another way of establishing a strength growth at early age. A higher initial concrete temperature prevents a rapid cooling at early age and by that facilitates a more rapid development of cement hydration process.
- c) *Covering and isolation*: Covering of concrete surface and isolation of formwork prevents heat losses during the concrete curing process. Examples of practical measures is to place isolated carpets onto newly poured concrete slabs or by using isolated formwork panels.
- d) *Use of heating system*: Other types of measures to facilitate the hardening process involve adding energy to the concrete structure. This could be achieved by using external heating systems (e.g. infrared heating) which temporarily increases the temperature at the concrete surface. Another way is to use internal heating systems which are embedded into the concrete structure, e.g. electrical heating cables.

It should be pointed out that the use of heated concrete and heating systems requires isolation or coverage of concrete surfaces in order to be effective. Moreover, measures such as c and d also require additional works on-site related to covering, isolation, and installation of heating systems.

### 3.4 Simulation of concrete temperature and strength development

Special-purpose simulation tools can be used for estimating concrete temperature and strength development for different structures, such as walls or slabs. In the Scandinavian countries, there exist different software tools, e.g. Hett II (Cementa 2011), PPB (SBUF 2015), AP TempSim, and AP Maturity (Aalborg Portland 2018). The software tools simulate the dynamic change in concrete temperature as a result of hydration of cementitious materials and heat losses to the surrounding environment. In principal, a concrete structure (typically a cross section) is divided into a mesh of connected elements. Each element represents a physical unit of the given structure. During simulation, the heat development (due to exothermic chemical reactions) for each element is calculated. In addition, the heat transfer between connected elements are also calculated resulting in a net gain (or loss) in temperature for each element. The calculation models also consider heat transfer to adjacent concrete structures and to the surrounding air. Also, the effects of using different types of formwork, insulation, or the supply of energy (e.g. heating systems) can be described. As a result, it is possible to estimate the effects of different measures to shield the fresh concrete during hardening against surrounding climate by employing different combinations of isolation of surfaces and use of heating systems. The essential parameters used by simulation tools (e.g. PPB) to estimate temperature development are schematically illustrated in figure 2.



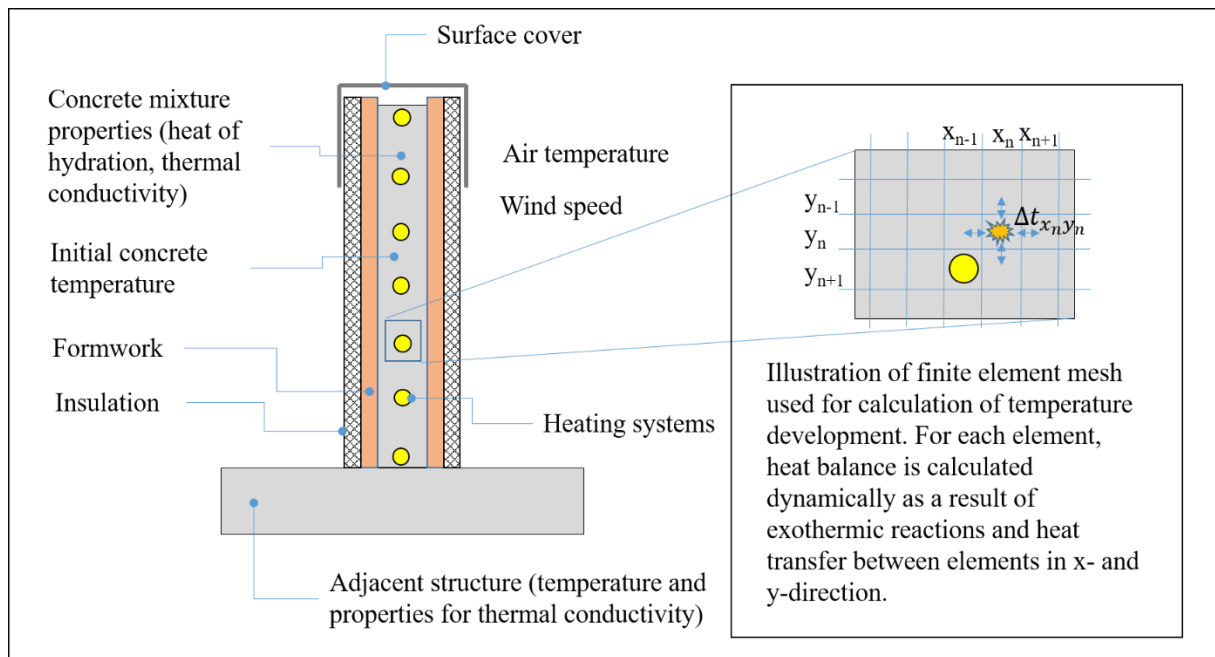

**Fig. 2.** Schematic illustration of essential parameters often used by simulation tools to estimate temperature development in concrete during hardening process.

The software tools estimate concrete strength development using simulated temperatures (as a result of chemical reactions, curing measures, and ambient climate) and the maturity theory described in section 3.2. For any given time, equivalent maturity age is calculated according to eq. 3 and 4 using simulated temperature history profile as input. The actual concrete strength is then determined using the calculated equivalent time and a tendency curve for the actual concrete type.

In this research, the software tool PPB (version 1.2.2) was used. The required input information are geometrical data, material data such as cement type, cement content, water-cement ratio, initial concrete temperature, formwork removal requirements, details about formwork and curing measures, e.g. type of formwork, isolation, heating systems etc. The software is provided with a material database containing maturity properties and tendency curves for a wide range of concrete mixtures typically used in Sweden.

## 4. Field studies

### 4.1 General description of field studies and data collection

Two separate field study projects (A and B) were conducted in order to collect necessary knowledge for developing the discrete-event simulation model and for validating the simulation software used to estimate formwork removal times. Even though, the two projects were separated in time and place, they possessed more or less the same basic prerequisites. For instance, both projects consisted of construction of a multi-story residential buildings with similar design complexity and built by the same contractor company. In addition, the construction method employed was more or less identical. However, the scope of data collection was different for the two field studies. In project A, the focus was on obtaining information about the concrete framework construction process and how it is affected by

weather and actions typically employed to shield construction against adverse weather conditions. In project B, the focus was on measuring temperatures and wind data in order to validate simulation tools used for prediction of formwork removal times. An overview of the field study projects are presented in table 1.

**Table 1.** Overview of field study projects and data collection methods.

Field study project	Building type	Concrete construction method (identical for A and B)	Data collection
A	Two six-story residential buildings.	Reinforcement method <ul style="list-style-type: none"> <li>• Rebar mesh (walls)</li> <li>• Cut-to-fit rebars and stirrups (slabs)</li> </ul> Formwork method <ul style="list-style-type: none"> <li>• Modular panels (walls)</li> <li>• Prefabricated table forms (slabs)</li> </ul> Concrete placement <ul style="list-style-type: none"> <li>• Pump (slabs)</li> <li>• Crane and skip (walls)</li> </ul> Prefabricated components <ul style="list-style-type: none"> <li>• Precast balcony slabs</li> <li>• Precast stair elements</li> <li>• Precast columns</li> </ul>	<i>What?</i> Process mapping, process data, practical experiences of weather and curing measures. <i>How?</i> On-site observations of physical works, collecting and reviewing project documents, interviews with site personnel.
B	Two eight-story residential buildings.	Same as field study A.	<i>What?</i> On-site measurements of temperatures in concrete wall and slab structures. <i>How?</i> Temperature sensors for measuring both air and concrete temperatures. Wind speed data obtained from nearby weather station.

#### 4.2 Field study A - Documentation of on-site construction process

The construction process was documented by on-site observations of physical activities and resources. Complementary information about process characteristics and common practices were obtained from project documentation and from interviews with site personnel.

The overall construction sequence can be summarized as follows: The frameworks in the two buildings were constructed simultaneously. For each building floor, concrete walls are divided into group of wall segments, denoted as a pour unit, where each unit is poured on a daily basis. The work cycle starts with construction of concrete walls by preparing, cleaning and erection of modular form panels. When form panels are properly installed, rebar, mechanical, electrical and plumbing works are then conducted. The wall cycle ends with closing the formwork and pouring concrete. The next day, formwork is removed and transferred to the next pour unit, either on the same floor or to a new floor located in the other building. At the new location, the wall cycle is then repeated. When all walls have been finished on a floor, preparation works for the next floor is started. Forming of the next floor slab is conducted using prefabricated table forms. Each building has its own setup of table forms where a specific table form has its predetermined position on each floor level. When removing the table form, it is lifted to the same position on the next floor level. When form tables are positioned, bottom layer of reinforcement bars and stirrups are placed and fixed followed by placement of pipes and



conduits for electrical, mechanical and plumbing systems. Prefabricated components such as precast balconies, stair elements and precast columns are then lifted and anchored in position. Finally, top layer of reinforcement bars are placed and all previous works are inspected before placing concrete is started. Each concrete floor slab is poured in one sequence using a concrete pump. The total floor cycle time in field study A was 14 days consisting of 6 days of wall activities and 8 days of slab activities including time for rearrangement and movement of resources (formwork etc.) to next work location. Since both wall form panels and table forms are reused during erection of the framework, the work process become dependent on that the concrete has gained sufficient strength in order to allow for formwork removal. During the site visits, the influences of weather and operational measures usually employed by the contractor in order to shield construction works against adverse weather, were also documented. A detailed description of the working process is presented in appendix A. The process description is formalized using IDEF1 notation language (Mayer et al. 1995) and outlines the process complexity, e.g. sequencing of work tasks, division of work flow into parallel processing, loopbacks depending on actual work flow status, current weather, or actual concrete strength level. This process description is also used as the basis for developing the discrete-event simulation model presented in section 7.

#### 4.3 Field study B - On-site measurements of concrete temperatures

Both concrete and ambient air temperatures were measured in field study B. The purpose of the measurements was to obtain temperature and wind data in order to validate a simulation tool used for predicting formwork removal times.

##### 4.3.1 Description of on-site measurements

Temperatures were measured on-site using Vema Distant sensor system enabling remote access to data wirelessly (<https://distant.vemaventuri.se/>). Concrete and air temperatures were measured every hour at different points in the concrete framework. The measurements were conducted by the contractor with assistance of the sensor system supplier. Complementary information about concrete mixtures and concrete curing conditions was retrieved from concrete supplier and field personnel on the construction site. Measured temperature data were retrieved by accessing the sensor system online service were data could be monitored in real time but also downloaded for further analysis.

In addition, wind speed data for corresponding time-period was retrieved from a nearby weather station located approximately 4 km away from the construction site.

The positions of the concrete temperature sensors, denoted as the measuring points (MP), are schematically illustrated in figure 3. The measurement points A-F (MP A-F) were located at floor levels 2 and 3 in building A and floor levels 2, 3 and 4 in building B. Concrete temperature sensors in MP B, MP D, and MP F respectively, are located inside wall structures. Each of these MP:s consist of up to three different sensor positions according to figure 3 (upper right part of figure). The position of concrete temperature sensor inside slab structure (MP A, MP C and MP E) is given in the lower-right part of figure 3. Air temperatures for each MP were also measured on-site using the climate sensors integrated into the sensor system nodes. The time period for measurements was from beginning of March 2018 to middle of April 2018.

The curing measures employed during this period consisted of shielding concrete walls against cold temperatures using insulated formwork panels, chemical admixture, and by increasing

concrete temperature. The same type of measures were also employed for shielding the concrete slab except that the table forms were not insulated. It is believed that the measures employed are rather typical given the actual construction period and geographical location of the project.

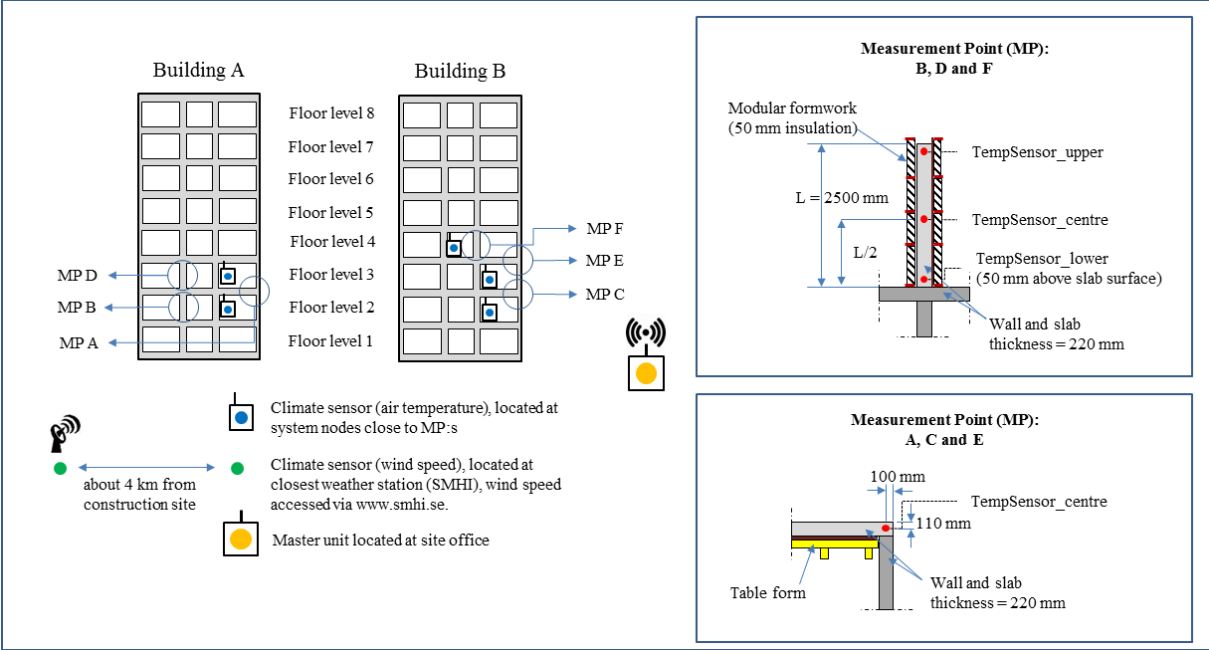

Fig. 3. Overview of measurement points in field study B.

The diagram to the left in figure 4 shows measured concrete temperatures and ambient air temperatures for MP F (center location of concrete wall). The right-hand side diagram shows corresponding measurements for concrete slab in MP A. Also, measured wind speeds at a nearby located weather station are shown for the actual time period. As can be seen in both diagrams, the concrete temperature first increases as a result of the chemical hydration heat and after some time, it decreases as the concrete is cooled by the ambient climate. The measured temperature data together with wind speed data were used to validate the simulation tool used to make estimations on formwork removal times (see section 4.3.2).

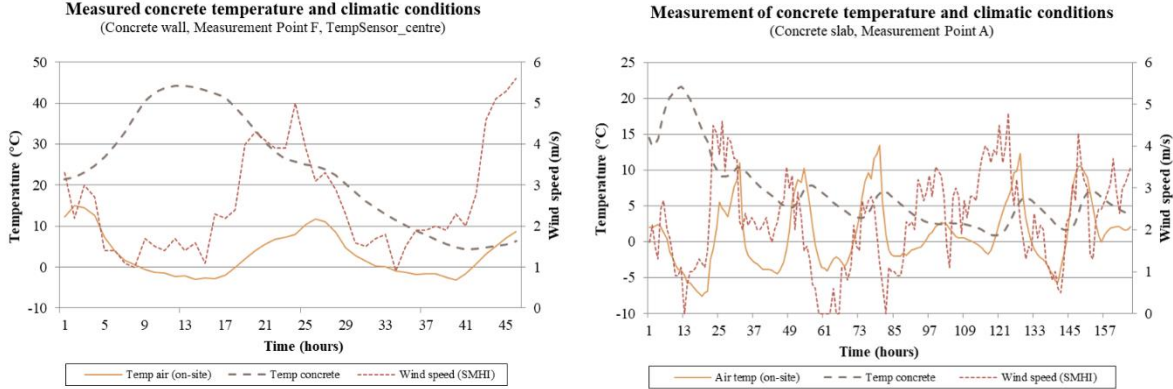

Fig. 4. Measured temperatures and wind speed in two measurement points in field study B.

#### 4.3.2 Comparison of simulated and measured temperatures

To validate the PPB simulation tool, comparisons between simulated and measured temperatures were conducted. For this purpose, temperatures and wind speed data measured in field study B were used as input to the simulation tool. All other conditions documented on site were also used as input data in order to mimic true conditions as far as possible. For instance, data about concrete geometry, formwork properties, positioning of sensors in concrete, concrete mixture properties etc. All parameters have been validated by measurements or by information provided by site-personnel or the material supplier (table 2). The simulated temperature profile was then compared with the measured temperature profile by importing measured concrete temperatures to the simulation software. In addition, also concrete strength development were calculated based on simulated and measured temperatures using the equivalent maturity method.

**Table 2.** Input parameters used for validation of simulation tool for estimating temperature and concrete development.

Parameters	Concrete wall (MP F)	Concrete slab (MP A)	Information source
Concrete thickness (mm)	220	220	Project documents
Cement type	CEM II/A-V 52,5 N	CEM II/A-V 52,5 N	On-site personnel
Concrete strength class	C28/35	C40/50	On-site personnel
Water-cement ratio (w/c)	0.58	0.42	On-site personnel
Cement content (kg/m <sup>3</sup> )	360	420	Concrete supplier
Initial concrete temperature (°C)	20	14	On-site sensor measurements
Air temperature (°C)	Variable according to fig. 3.	Variable according to fig. 3.	On-site sensor measurements
Wind speed (m/s)	Variable according to fig. 3.	Variable according to fig. 3.	SMHI weather station (ID: 86340)
Formwork properties	Modular formwork, steel frame with 19 mm plywood surface.	Table forms with 19 mm plywood surface	On-site personnel
Surface cover/formwork insulation	Formwork insulated with 50 mm EPS foam (intermittent)	None	On-site personnel
External / internal heating	None	None	On-site personnel

In figure 5, an example of simulated and measured concrete temperature profile for the concrete slab according to MP A is shown (diagram to the left). As seen, there is an initial difference between measured and simulated temperature during the first 2-days. This could be explained by the effect of accelerated admixture used in the concrete mix. Accelerated admixture speeds up the chemical hydration resulting in that the internal hydration heat begins earlier than a concrete mix without admixture. Since the concrete type used by the simulation tool was not adjusted for the effects of accelerated admixture, a delay occurs in when simulated temperature starts to increase (as a result of hydration heat) compared to measurements. This is clearly indicated by the time-lag between the temperature peaks around 20 hours. It can be noticed that the simulated and measured level of maximum temperature is comparable. In addition, one can also notice that during the cooling phase, i.e. after the maximum temperature is reached, the decrease in temperature follows more or less the same curve. Finally, the difference in early temperature profile has a minor effect on concrete strength development as can be seen in figure 5 (diagram to the right). In figure 6, simulated versus measured temperatures are given for the

concrete wall according to MP F (diagram to the left) and corresponding concrete strength estimation based on simulated and measured temperatures (diagram to the right). As seen, the simulated temperatures is somewhat underestimated compared to measured temperatures. Neglecting the use of chemical additives in concrete mixture and/or underestimating the actual formwork isolation factor in the simulation model may explain the difference between simulated and measured temperatures. However, the peak temperatures are more or less the same and the difference in calculated strength is relatively small. It can also be noticed both from simulated and measured temperatures, that the concrete structure is not affected by ambient climate during the cooling phase as much as was the case for the concrete slab. Obviously, the isolated formwork protects the concrete against ambient climate in an effective way. Comparing simulated and measured temperatures for other measurement points, similar results as for MP A and MP F were obtained.

To summarize, it can be concluded that the simulation tool is capable of estimating the temperature profile even though the effects of accelerated admixture in concrete mix is neglected. It can also be concluded that validation of software tools for prediction of concrete strength require not only knowledge about hydration parameters and tendency curves for the concrete mixtures used, but also detailed knowledge about the measurement point as well as the conditions during the curing process.

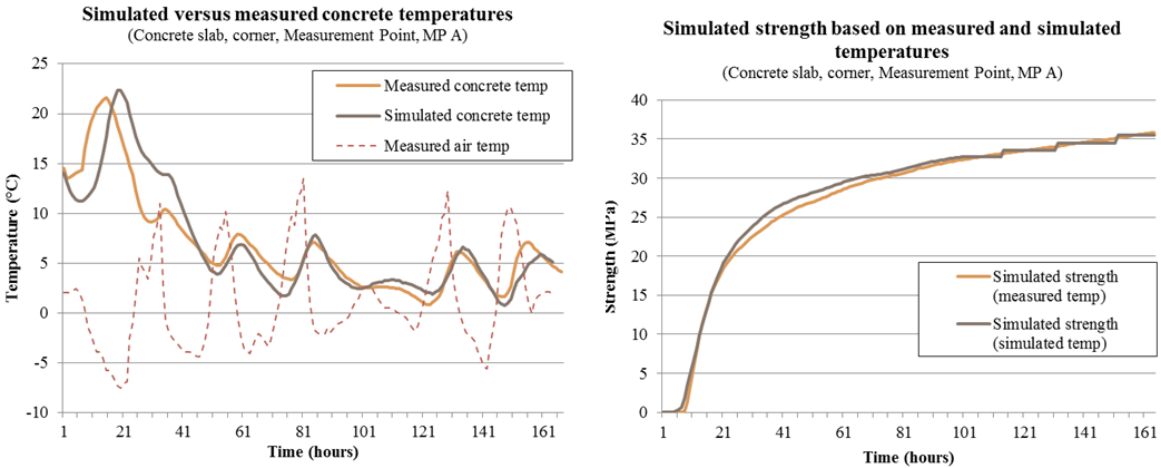

**Fig. 5.** Simulated versus measured temperature (left diagram) and concrete strength development (right diagram) for concrete slab.

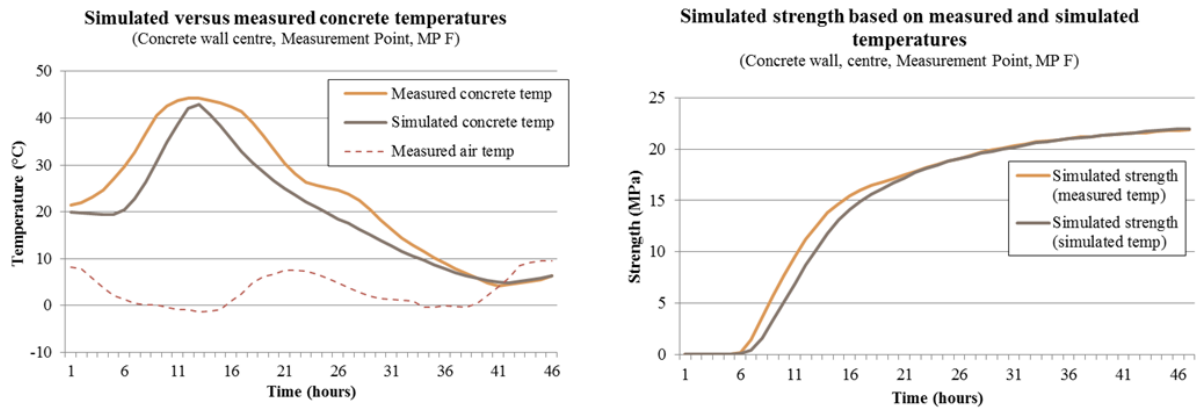

**Fig. 6.** Simulated versus measured temperature (left diagram) and concrete strength development (right diagram) for concrete wall.

## 5. Weather data analysis

Since weather conditions vary due to seasonal changes but also on daily or even hourly changes, it is necessary to analyse weather data that have necessary resolution. For instance, wind speed vary on hourly basis and actual wind condition determine if a lifting operation can be performed (or not). This may have significant effects on workflow productivity. Other examples where hourly updates of weather data is needed is during the curing process of concrete. The first 6-12 hours of temperature and wind conditions have a significant effect on concrete strength development. Accordingly, weather statistics with hourly resolution were retrieved from the Swedish Meteorological and Hydrological Institute (SMHI). Data sets for three different geographical locations (Malmö, Stockholm, and Umeå), were compiled and analysed. The three locations were chosen since they represent three different climate zones in Sweden. The weather data included hourly records on temperature, precipitation, and wind speed covering a time period of 20 years (1997-2016). However, for Umeå, it was only possible to compile complete data sets for a 10year period (2007-2016). Each data set was controlled for completeness. In cases of missing data points, they were completed manually by interpolating between closest known data points. In Sweden, official statistics on precipitation are expressed in melted phase (mm/hour). But since snow depth depends on actual temperature where 1 mm precipitation corresponds to 10 mm snow around zero degrees. At colder temperatures, the same amount of precipitation results in an increased snow depth. This phenomena is commonly known as the ‘fluffiness factor’. As a result, a general relationship, given in figure 7, was employed to correct precipitation records with respect to the fluffiness factor using actual temperature data (SMHI 2013).

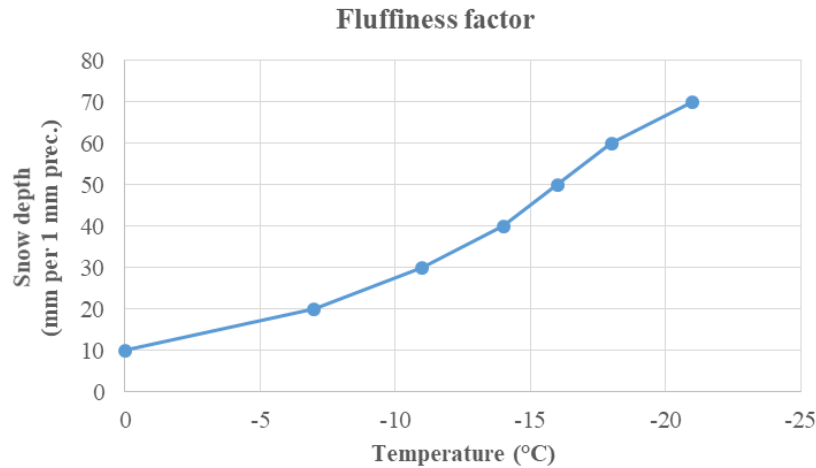

**Fig. 7.** The fluffiness factor describing the relation between temperature and snow depth (SMHI 2013).

From the data sets, a normal year for each geographical location was identified. A normal year is identified as the year that had least deviation in annual precipitation, average temperature, and average wind speed compared with average values for the total period of 20 years (or 10 years for Umeå). In order to reflect the influence of more unusual weather, the years with highest and lowest annual mean temperature were also identified for one location (Stockholm). To limit the number of scenarios, only one geographic location was chosen. Since Stockholm represent a majority of construction activities in Sweden, it was interesting to select this location as an illustrative case. Table 3 summarizes the resulting years used as basis for further analysis in this report.

**Table 3.** Overview of years with different weather conditions typical for three geographical locations.

Geographical location	Years with typical weather conditions		
	Normal	Warm	Cold
Malmö	2006	n/a	n/a
Stockholm	1997	2014	2010
Umeå	2007	n/a	n/a

## 6. Simulation of formwork removal times

### 6.1 Introduction

The PPB simulation tool version 1.2.2 was used to simulate formwork removal times for various concrete types, curing measures and climate conditions. The accuracy in predictions has been evaluated in section 4.3.2 with satisfying outcome. Formwork removal times were simulated for both vertical and horizontal formwork. The results were compiled and structured in a way so it could be used in the DES-model as described in section 7.

### 6.2 General prerequisites for simulation

Formwork removal time is defined as the time between finishing of concrete pouring and when concrete has gained minimum compression strength to allow removal of formwork. Four types of rules (described in section 3.2) related to concrete curing temperatures and compression strength were used as input to simulations;

1. Minimum compression strength for enabling removal of vertical formwork was set to 6 MPa.
2. Minimum strength requirement for removal of horizontal formwork was set to 70% of 28 day strength for prescribed concrete class (C25/30). Note that only structural requirements on concrete quality was considered. Other requirements on concrete quality, e.g. to fulfill a quick drying out process were not in focus of this study.
3. To avoid risk of early freezing, the compression strength must have gained at least 5 MPa before concrete temperature drops below zero degrees.
4. In order to also avoid high concrete temperatures which are negative for the long-term strength, a rule preventing temperature to rise above 60 °C was also applied. This value was used since it is defined as a default setting in the simulation tool used.

Different scenarios related to concrete types, curing measures and weather conditions were simulated. A schematic illustration of the vertical and horizontal formwork systems and the different parameters considered in the simulation scenarios are presented in figure 8. The different scenarios related to concrete types and curing measures are described in section 6.3.2 and section 6.3.3 respectively. Weather conditions were systematically altered for each type of concrete and curing measure. The temperature was studied in the range of -25 to +10 °C with 5°C interval. Wind speed was studied at two levels: calm/breeze conditions (0 to 6 m/s) and windy conditions (> 6 m/s).

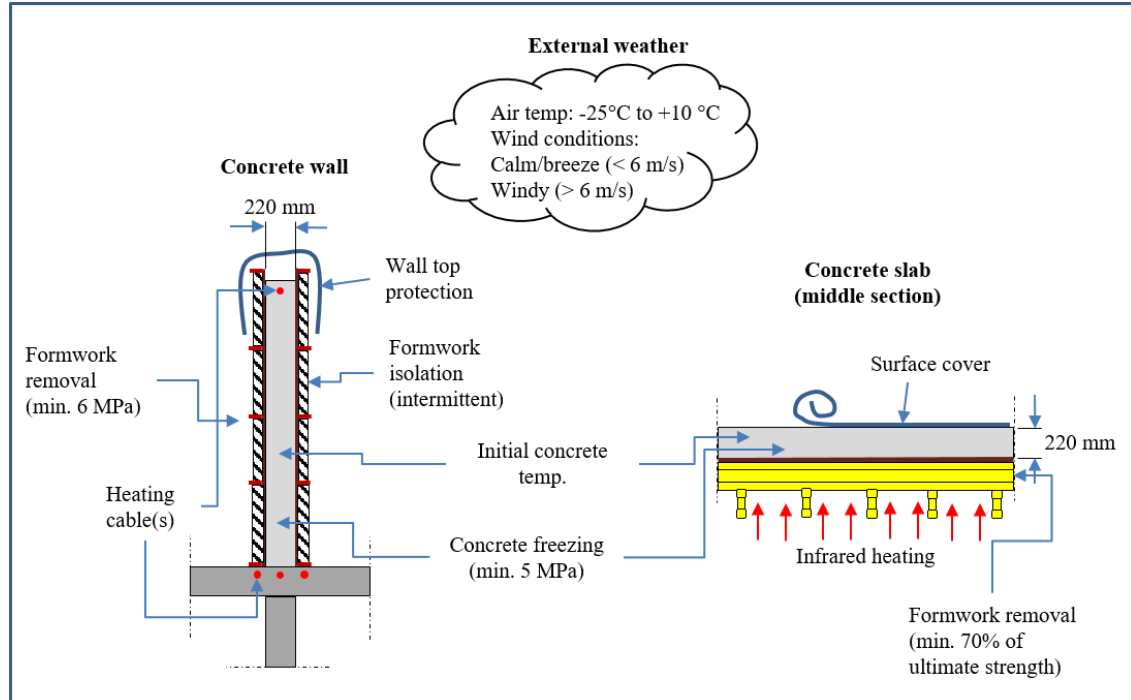

**Fig. 8.** Outline of the theoretical setup used as a basis for simulation of formwork removal times for walls and slab structures.



### 6.3 Concrete mixtures

To study the effect of using climate improved concrete types on formwork removal times, six concrete mixtures were used as a basis for the simulations. The concrete mixtures reflect some of the short-term ambitions for reducing carbon emissions according to the Swedish concrete association (Svensk Betong 2019). In table 4, an overview of the concrete mixtures are presented. It should be noted that these concrete types are limited for use in indoor environments according to exposure classes X0 and XC1 (SIS 2016). A fly ash Portland cement type (CEM II/A-V 52.5 N) was used in all concrete mixtures. WSTD refers to a standard concrete type commonly used for wall structures whereas SSTD refers to a standard concrete mixture typically used in floor slabs. W10 refers to concrete types used for walls with 10% lower climate impact compared to standard mixtures. Similarly, S10 refers to a concrete mixture used in floor slabs with 10% lower climate impact. Finally, W25 and S25 refers to concrete types for walls and slabs with 25% lower carbon emissions. It should be noted that concrete types such as S25 are not suitable in floor slabs if requirements related to a quick drying out of concrete have to be fulfilled.

**Table 4.** Overview of concrete types used for simulation of formwork removal times. The concrete types used fulfill requirement for use in exposure classes X0 and XC1.

Concrete wall type	Strength class	Cement content (kg/m <sup>3</sup> )	Concrete slab type	Strength class	Cement content (kg/m <sup>3</sup> )
WSTD	C30/37	360	SSTD	C40/50	420
W10	C28/35	325	S10	C35/45	380
W25	C25/30	270	S25	C25/30	320

### 6.4 Concrete curing strategies

Three different strategies A, B, and C were simulated in order to shield concrete against cold weather during the curing process. A detailed description of the measures included in each strategy is given in table 5. Strategy A represents a basic level for protection measures, strategy B is somewhat more extensive compared to A and strategy C represents the most advanced level.



**Table 5.** Description of curing strategies for concrete walls and slabs.

Concrete curing strategy	Concrete walls	Concrete slabs
A	<ul style="list-style-type: none"> <li>• Initial concrete temp = 20°C</li> <li>• Formwork panels: 19 mm plywood with 50 mm intermittent EPS isolation.</li> <li>• Cover of formwork top with tarpaulin sheets (place one hour after pouring and removed 17 hours after).</li> </ul>	<ul style="list-style-type: none"> <li>• Initial concrete temp = 20°C</li> <li>• Table forms: 19 mm plywood</li> <li>• Surface cover: 10 mm high-performance insulation placed 1 hour after pouring and removed after 24 hours.</li> <li>• 50 mm isolation along the edge of concrete slab</li> </ul>
B	<ul style="list-style-type: none"> <li>• Initial concrete temp = 25°C</li> <li>• Formwork panels: 19 mm plywood with 50 mm intermittent EPS isolation.</li> <li>• Cover of formwork top with tarpaulin sheets (place one hour after pouring and removed 17 hours after).</li> <li>• Heating cables (30 W/m) placed in top (1 cable) and bottom of wall (3 cables)</li> </ul>	<ul style="list-style-type: none"> <li>• Initial concrete temp = 25°C</li> <li>• Table forms: 19 mm plywood</li> <li>• Surface cover: 10 mm high-performance insulation placed 1 hour after pouring and removed after 24 hours.</li> <li>• 50 mm isolation along the edge of concrete slab</li> </ul>
C	<ul style="list-style-type: none"> <li>• Same measures as “Level B”.</li> </ul>	<ul style="list-style-type: none"> <li>• Initial concrete temp = 25°C</li> <li>• Table forms: 19 mm plywood</li> <li>• Surface cover: 10 mm high-performance insulation placed 1 hour after pouring and removed after 24 hours.</li> <li>• 50 mm isolation along the edge of concrete slab</li> <li>• Use of infrared heaters (100 W/m<sup>2</sup>) from the underside of the poured concrete slab. Heaters are operated until 7 days after pouring.</li> </ul>

### 6.5 Formwork removal times

In total, 240 individual scenarios of formwork removal times were simulated covering both vertical and horizontal formwork. The results were then structured and incorporated into a database linked to the DES-model as described in section 7. In table 6, a sample of simulated removal times for horizontal formwork based on concrete types SSTD, S10 and S25, curing strategies A and C, and a complete set of weather conditions are presented. Formwork removal times are expressed in hours and corresponds to the time between the end of concrete pouring and when concrete has gained sufficient strength. For instance, for concrete configuration S25 with winter protection strategy A, the formwork removal time for windy conditions and 0 degrees is equal to 315 hours. Formwork removal times marked with “error” refers to that early freezing has occurred for the actual combination of concrete type and curing strategy. Obviously, using such a combination is not applicable for the current weather condition. A complete set of formwork removal times used by the DES-model during simulation experiments are given in appendix (tables A.1 and A.2).

**Table 6.** Simulated formwork times for concrete walls for varying concrete types, curing methods and weather conditions.

<b>Formwork removal times (horizontal formwork)</b>										
Hours between end of concrete pour and formwork removal (concrete strength > 21 MPa*)										
Freezing constraint: Concrete strength > 5 MPa when air temp. < 0°C. Otherwise “error”.										
Concrete configuration	Curing strategy	Wind condition 0-6 m/s >6m/s	Air temperature (°C)							
			-25	-20	-15	-10	-5	0	5	10
SSTD	A	0-6	error	error	32.5	24.9	21.8	19.8	18	16.8
SSTD	A	>6	error	error	error	error	29.5	23	20	18
S10	A	0-6	error	error	error	33	26.8	23.8	22	20.8
S10	A	>6	error	error	error	error	61	29.5	24.4	22
S25	A	0-6	error	error	error	error	error	259	159	131
S25	A	>6	error	error	error	error	error	315	183	131
...	...	...	...	...	...	...	...	...	...	...
SSTD	C	0-6	19.5	17.8	19.3	15.5	14.8	14	13.3	12.8
SSTD	C	>6	error	22.3	19.5	17.5	16.3	15	14	13.3
S10	C	0-6	24.3	22	20.5	19.5	18.8	18	17.5	17.5
S10	C	>6	error	31	24	21.8	20.3	19	18.3	17.5
S25	C	0-6	error	error	error	error	240	188	184	192
S25	C	>6	error	error	error	error	error	208	180	172

\*) >70% of 30 MPa according to the final strength of prescribed concrete class C25/30.

## 7. Discrete-event simulation model

### 7.1 General description

The model was developed using ExtendSim version 9 as the software platform ([www.extendsim.com](http://www.extendsim.com)). More details about the simulation software can be found in (Krahl 2003). The structure of the DES-model is outlined in figure 9. As seen, the model contains two sub-models representing the construction of concrete frameworks in two separate multistory buildings. Each sub-model contains a process description of the concrete framework erection process according to figure A.1 in appendix. The model simulates the duration of both individual work tasks as well as the overall construction process. It continuously keeps track of the overall workflow (building, floor slab level, wall unit etc.) as well as timing of work tasks (start and finish) during the run of the simulation. In addition, the model automatically controls the use of resources involved in various work tasks, e.g. labour, reusable formwork, tower crane. Data describing work locations, construction sequence, productivity, and resource usage are imported and stored in internal databases. Weather statistics describing temperature, precipitation, and wind speed hour by hour are also imported to the model. Simulated formwork removal times based on different concrete types, curing strategies, and weather conditions, are also imported and stored in a database. During the run of the simulation, the model constantly updates current weather conditions. The model dynamically accounts for the impact of weather on work task productivity as described in section 7.2. It also considers the impact of weather on formwork removal times as described in section 7.3.

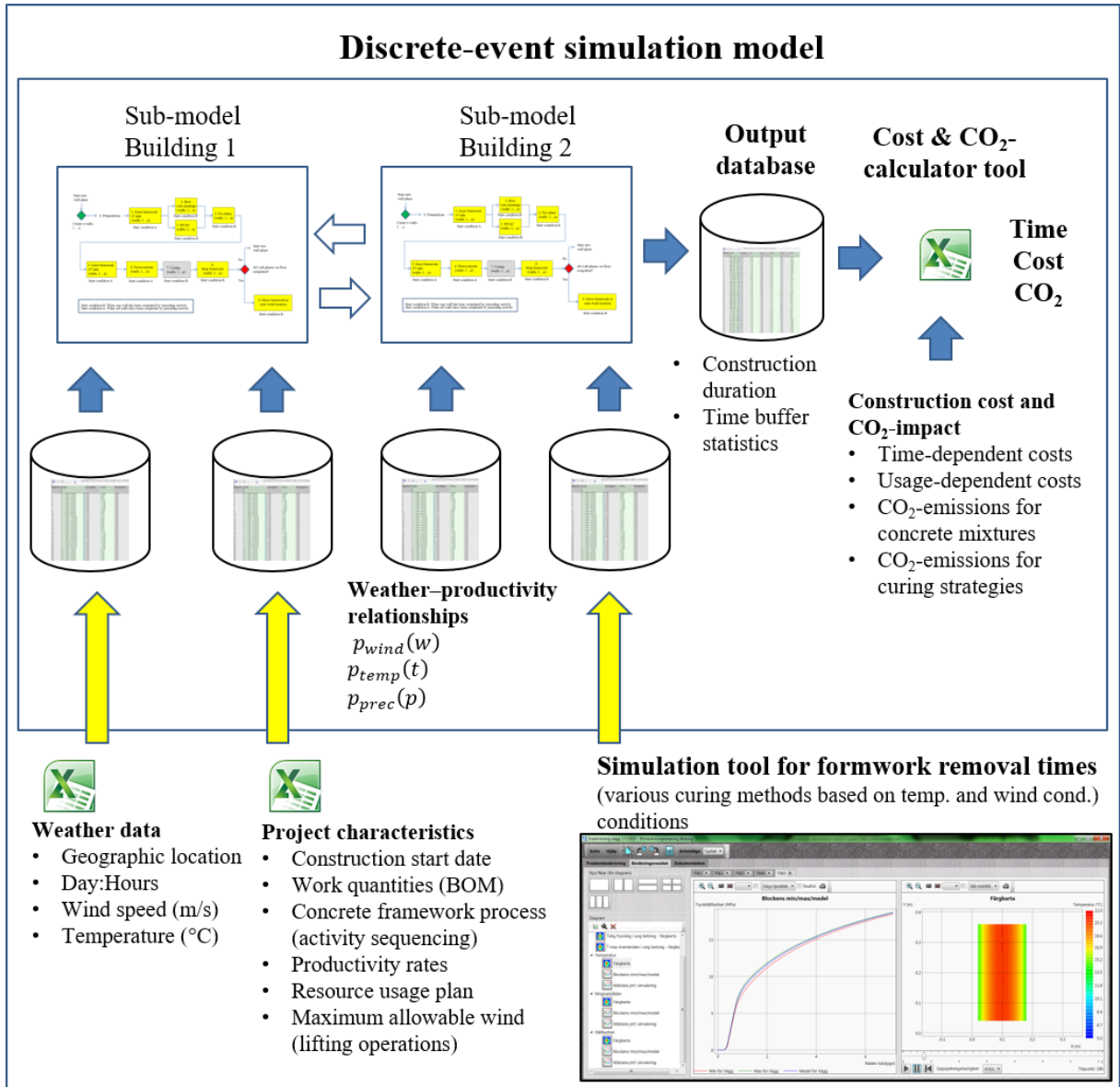

**Fig. 9.** Overview of the simulation model and its system components.

## 7.2 Algorithm for considering effects of weather on work task productivity

The procedure and specific algorithms for describing the effect of weather conditions on specific work tasks are based on research presented in Larsson and Rudberg (2019). The procedure can be summarized as follows: Functions describing the relation between productivity loss and temperature ( $p_{temp}$ ), precipitation ( $p_{prec.}$ ), and wind speed ( $p_{wind}$ ) are used. These functions are formulated based on previous research findings. Each of these functions describe the percentage loss in productivity. The combined effect of temperature, precipitation and wind speed is then described by a weather factor ( $wf$ ) according to eq. 5.

$$wf = p_{wind}(w) \times p_{temp}(t) \times p_{prec.}(p) \quad (5)$$

where  $p_{wind}(w)$  defines the effect on productivity as a function of wind speed  $0 \leq p_{wind}(w) \leq 1$ ;  $p_{temp}(t)$  defines the effect on productivity as a function of temperature  $0 \leq p_{temp}(t) \leq 1$ ;  $p_{prec.}(p)$  defines the effect on productivity as a function of precipitation intensity;  $w$  = wind speed (m/s);  $t$  = temperature (°C);  $p$  = precipitation intensity (mm/h). The weather factor ( $wf$ )

varies between 1 and 0, in which 1 indicates no loss in productivity due to weather effects and 0 means a 100% loss in productivity (equal to work stoppage). The simulation model dynamically accounts for the effect of weather according to the following procedure;

1. At every hour, the simulation model updates weather conditions (wind speed, temperature, precipitation) from a climate database. The model also updates status of ongoing working processes and the location of those.
2. Depending on actual temperature, the type of precipitation is determined. If temperature is above 0, then the model assumes rain. If temperature is equal to zero or below, the model assumes snowfall. The model also accounts for the temperature effect on snow depth according to the fluffy factor index (figure 4). In addition, wind speed is adjusted to current altitude at which construction work is taken place using the power law wind profile ([WebMet 2002](#)).
3. Actual wind speed is then compared with maximum allowed wind speed for lifting operations. Threshold values are user defined and imported to the model at the beginning of the simulation. Different types of lifting operations can have different threshold values, e.g. lifting of large formwork panels have a lower threshold value compared to lifting of reinforcement bars.
4. If the wind speed is higher than maximum allowed wind speed, the model stops until the next update of weather conditions which occur the next hour. This control sequence is looped until actual wind speed allows to proceed with lifting operation.
5. The weather factor ( $wf$ ) is then calculated using eq. 5 and current weather conditions. The weather factor is then used to adjust work task duration as a result of the combined effect of current weather factors. More details about the exact procedure is described in [Larsson and Rudberg \(2019\)](#).

### 7.3 Algorithm for considering effects of weather on formwork removal times

The algorithm for considering effects of weather on horizontal formwork removal times are outlined in figure 10. At beginning of the simulation, a user selects a desired curing strategy for both concrete walls and slabs. By doing this, the model has access to corresponding formwork removal times for different weather conditions during the simulation. As mentioned earlier, the model continuously updates ongoing working processes and keeps track of future pouring activities. Referring to figure 10, when a floor slab is ready to be poured (equal to the finish of act. 32 in figure A.1, appendix), current time is set to  $t_{now}$  and actual temperature ( $temp_{now}$ ) and wind speed ( $wind_{now}$ ) are obtained from the climate database. The model also reads future temperatures and wind speeds for the next seven days (168 hours). Next, mean temperature ( $temp_m$ ) and wind speed ( $wind_m$ ) is calculated for the actual time period. Calculated mean wind speed is then adjusted to actual altitude at which work is ongoing by using the equation describing the power-law wind profile. The same procedure is used for vertical formwork even though the time period for future weather is 12 hours instead of 168 hours. A description of the precise algorithm for vertical formwork used in the model is described in [Larsson \(2019\)](#).

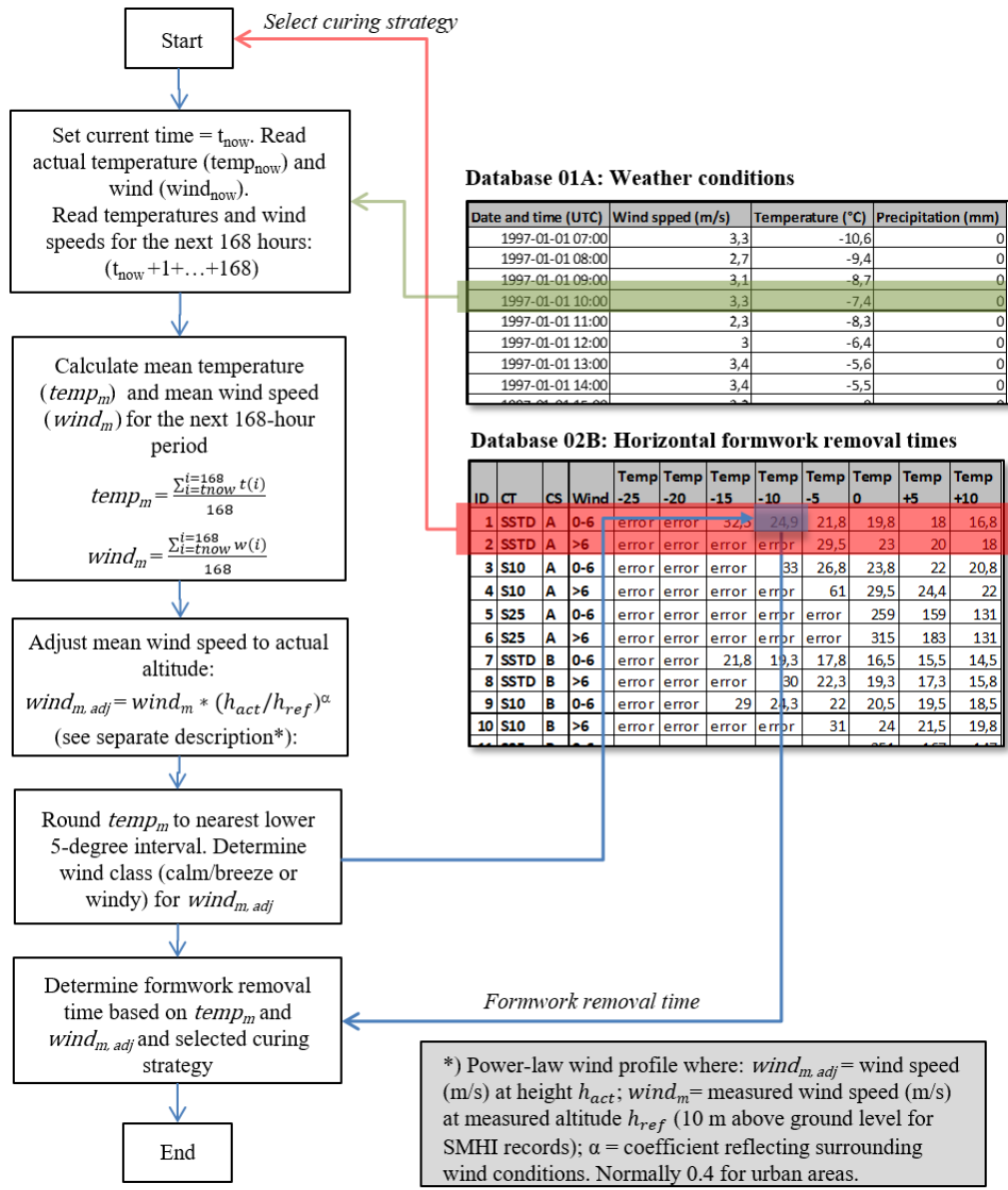

**Fig. 10.** Developed algorithm for determine the effect of weather on formwork removal times.

The model not only takes into account the effect of weather on the curing process, but also takes into account whether extra winter measures are needed to protect the concrete structure against ambient weather conditions. The algorithm used to consider the need for extra winter-related measures in connection with pouring of concrete walls and floor slabs are described in figure 11. The figure shows a section of the process diagram according to figure A.1 in the appendix. In junction elements J4 and J11, a control of current and future weather conditions are made, which are then compared against threshold conditions for when winter measures should be employed. For walls, winter measures are employed when the average temperature for the coming 12-hour period is less than 0 °C or if the temperature is less than 5 °C and the wind speed is above 6 m/s on average. The same principle is used for floor slabs, although average temperature and average wind speed are calculated for the subsequent 168 hours. Which measures performed depend on the curing strategy selected according to table 5. During a simulation, the model keeps track of the number of times a particular curing method is

employed at walls and floor slabs. These variables are also used for calculating costs and carbon emissions as described in sections 7.5 and 7.6.

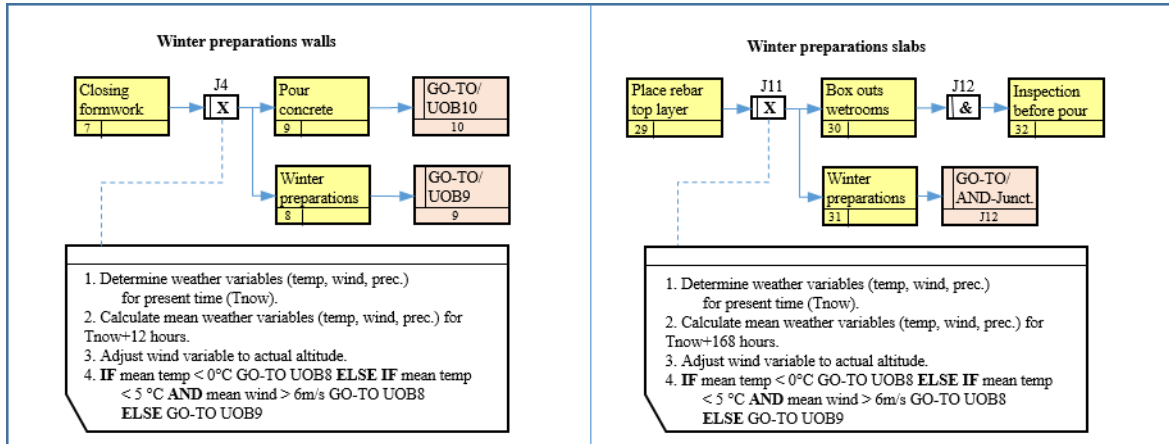

**Fig. 11.** Logical modelling and coding describing the need for winter preparations as a function of actual weather conditions.

#### 7.4 Calculation of time buffers during concrete curing

Removal of formwork assume that previous work tasks are finished (workflow-related condition) but also that the concrete structure has gained sufficient strength (material-related condition). In a perfectly synchronized production system, the workflow and material-related conditions are fulfilled simultaneously. If the workflow is ready to remove formwork but concrete strength is lower than the threshold value to allow formwork removal, then the workflow is interrupted which may result in project delays and increased costs. If the concrete strength allows for formwork removal but the workflow is not ready, it might indicate the use of unnecessary high-quality concrete types and/or the use of too extensive curing-related measures which leads to increased project costs and environmental impact. To facilitate the analysis of synchronization of workflow and concrete curing, a *BuffTime* value is introduced. The *BuffTime* denotes the time between when concrete strength allows for removal of table forms (material-related condition) and when the workflow is ready to remove table forms (workflow-related condition).

$$BuffTime = \left[ \sum_{i=1}^n \frac{(Time_{UOB12}(i) - Time_{UOB36}(i-1))}{n} \right] / 24 \quad (6)$$

where *BuffTime* defines mean buffer time (days);  $n$  = number of floor slabs in project;  $Time_{UOB12}(i)$  = time in hours when work task UOB12 (lifting of infill materials) at floor level  $i$  is finished. UOB denotation according to figure A.1 in appendix;  $Time_{UOB36}(i - 1)$  = time in hours when concrete slab at floor level  $i - 1$  has reached sufficient strength to allow removal of formwork. A positive *BuffTime* value means that concrete strength (UOB36) has reached sufficient strength before workflow is ready to strip formwork (UOB12). A negative value or a value close to zero indicates that the workflow is interrupted since concrete has not reached sufficient strength. It should be noted that it exists no precise *BuffTime* value describing an ideal situation. Selection of concrete types and curing methods should always be synchronized



with the overall concrete construction workflow. That means reducing BuffTime as much as possible without risking delays in formwork removal.

### 7.5 Cost data

To consider the effects of weather on construction costs, a calculation tool was developed in excel. The calculation tool uses total simulated duration of concrete frameworks as input. The tool contains data about time-dependent and usage-dependent costs. The cost data is limited to typical resources used for construction of the concrete framework. In addition, only cost items have been considered that either are time-dependent (affected by extended duration) or are affected by the choice of concrete types and curing strategy. Accordingly, the cost tool do not provide a complete cost analysis but is capable of showing on relative differences between relevant production alternatives. Cost data has been collected from interviews and access to data via contractor companies and material suppliers. In addition, cost data were obtained from reports where costs of concrete frameworks have been reported. Data from different sources were compiled and compared in order to verify the reliability for each cost item. Costs were index-adjusted according to Swedish annual price factor index when data were originated from sources based on different time-periods (SCB 2020). The different cost items are outlined in table 7 and the mathematical expression for calculating costs are given in equation 7. In table A4 in appendix, more details about cost data used in this report are presented.

**Table 7.** Description of cost items used in the simulation model.

Cost item	Name	Denotation	Description of included cost items
Time-dependent	General site resources	$GSR$ (cost/day)	<ul style="list-style-type: none"> <li>Rental costs for tower crane</li> <li>Wages for site personnel (labor and management)</li> <li>Rental costs for site personnel cabins</li> <li>Rental costs for hand tools and machinery</li> <li>Rental costs for hoists and scaffolding systems</li> <li>Costs for electricity and energy usage</li> <li>Costs for site cleaning and waste management</li> </ul>
	Formwork walls	$FW_{walls}$ (cost/day)	<ul style="list-style-type: none"> <li>Rental costs for wall formwork systems</li> </ul>
	Formwork slabs	$FW_{slab}$ (cost/day)	<ul style="list-style-type: none"> <li>Rental costs for table forms</li> <li>Rental costs for temporary support (shoring)</li> </ul>
Usage-dependent	Curing methods walls	$CM_{walls}$ (cost/use)	<ul style="list-style-type: none"> <li>Costs for formwork isolation</li> <li>Costs for usage of heating cables</li> <li>Costs for usage of preheated concrete</li> </ul>
	Curing methods slabs	$CM_{slab}$ (cost/use)	<ul style="list-style-type: none"> <li>Concrete surface cover</li> <li>Heating system, e.g. infrared heating</li> <li>Costs for usage of preheated concrete</li> </ul>
	Concrete wall	$CON_{walls}$ (cost/vol)	<ul style="list-style-type: none"> <li>Costs related to concrete type (e.g. strength class)</li> <li>Including costs for transportation, additional cost for winter season, and extra cost for heated concrete.</li> </ul>
	Concrete slabs	$CON_{slab}$ (cost/vol)	<ul style="list-style-type: none"> <li>Costs related to concrete type (e.g. strength class)</li> <li>Including costs for transportation, additional cost for winter season, and extra cost for heated concrete.</li> </ul>

$$Cost = (GSR + FW_{walls} + FW_{slab}) \times Time + (CON_{walls} \times Vol_{walls}) + (CON_{slab} \times Vol_{slab}) + (CM_{walls} \times Use_{walls}) + (CM_{slab} \times Use_{slab}) \quad (7)$$

where  $Time$  = Total construction duration (days);  $Vol_{walls}$  = volume of concrete walls ( $m^3$ );  $Vol_{slab}$  = volume of concrete slab ( $m^3$ );  $Use_{walls}$  = number of walls that the actual curing method has been applied to during simulation, see section 7.3;  $Use_{slab}$  = number of slabs that the actual curing method has been applied to during simulation.

## 7.6 Carbon emission data

The calculation tool also determines carbon emissions for selected concrete types and curing strategy. Data on carbon emissions for cement and concrete types have been retrieved from environmental product declarations describing environmental impact of building products (CEN 2012). The Environmental Product Declarations, (EPD:s are based on ISO-standards for life cycle assessment of environmental impact (ISO 2006). The data includes sourcing, production and transport of materials (A1-A3). In addition, carbon emissions due to production of heated concrete and the usage of electrical heating systems (cables and infrared heaters) are also included. Carbon emissions have been calculated according to equation 8.

$$CO_2 = (CO2_{CON,walls} \times Vol_{walls}) + (CO2_{CON,slabs} \times Vol_{slab}) + (CO2_{CM,walls} \times Use_{walls}) + (CO2_{CM,slabs} \times Use_{slab}) \quad (8)$$

where  $CO2_{CON,walls}$  = Carbon emissions for actual concrete type used in walls ( $kg/m^3$  concrete);  $CO2_{CON,slabs}$  = Carbon emissions for actual concrete type used in floor slabs ( $kg/m^3$  concrete);  $CO2_{CM,walls}$  = Carbon emissions for selected curing method used for concrete walls ( $kg/use$ );  $CO2_{CM,slabs}$  = Carbon emissions for selected curing method used for concrete slabs.

An overview of carbon emissions for each concrete configuration and curing strategy is given in table 8. Carbon emissions for  $CO2_{CON, Walls}$  and  $CO2_{CON, Slabs}$  have been determined using data on carbon emissions for the cement type used in all concrete mixtures (Cementa 2019). This value has been adjusted to include steps A1 to A3 for the concrete mixture by using complementary data from EPD documents for general Swedish concrete types (Svensk Betong, 2017). Moreover,  $CO_2$  emissions due to the use of heated concrete (20 or 25 °C) have also been added. These values have been determined using knowledge about energy demand for production of heated concrete (Cementa 2007). The relative difference between concrete configurations WS-STD, WS-10, and WS-25, aligns with the ambitions of reducing carbon emissions declared by the Swedish Concrete Industry Association (Svensk Betong 2017).

**Table 8.** Carbon emission data for each concrete configuration and curing strategy.

Concrete config.	Curing strategy	$CO2_{CON, Walls}$ ( $kg/m^3$ )	$CO2_{CON, Slabs}$ ( $kg/m^3$ )	$CO2_{CM, Walls}$ ( $kg/use^1$ )	$CO2_{CM, Slabs}$ ( $kg/use^2$ )
WS-STD	A	266	309	0	0
WS-10	A	241	280	0	0
WS-25	A	201	237	0	0
WS-STD	B	267	311	18	0
WS-10	B	242	282	18	0
WS-25	B	202	238	18	0
WS-STD	C	267	311	18	5355
WS-10	C	242	282	18	5355
WS-25	C	202	238	18	5355

<sup>1)</sup> Use = one pour unit of walls.

<sup>2)</sup> Use = one pour unit of floor slab



The term  $CO2_{CM,Walls}$  considers carbon emissions related to curing measures of concrete walls and is determined according to equation 9.

$$CO2_{CM,Walls} = \frac{L \times Nbr_{ClS} \times Power_{ClS} \times OT \times CO2_{El}}{1000} \quad (9)$$

where  $L$  = Length of concrete wall (m);  $Nbr_{ClS}$  = Number of heating cables in concrete wall unit;  $Power_{ClS}$  = Power capacity of heating cable (W),  $OT$  = Operating time the heating cables are in use (hours),  $CO2_{El}$  = Carbon emissions emitted due to usage of electricity needed by the heating cables (kg CO<sub>2</sub>/kWh). The input values to equation 9 are given by the input variables used in the simulations described in chapter 6.

The term  $CO2_{CM,Slabs}$  considers carbon emissions related to curing measures of concrete slabs.  $CO2_{CM,Slabs}$  is calculated according to equation 10.

$$CO2_{CM,Slabs} = Nbr_{Hts} \times Power_{Hts} \times EF \times CO2_{El} \times 24 \times OT \quad (10)$$

where  $Nbr_{Hts}$  = Number of infrared heaters needed to provide sufficient heat beneath a newly poured concrete surface;  $Power_{Hts}$  = Power capacity of infrared heater (W);  $EF$  = Efficiency factor of energy source used;  $CO2_{El}$  = Carbon emissions emitted due to usage of electricity needed by the infrared heaters (kg CO<sub>2</sub>/kWh);  $OT$  = Operating time the infrared heaters are in use (days). The input values to equation 10 are also here given by the input variables used in the simulations described in chapter 6.

The number of infrared heaters needed ( $Nbr_{Hts}$ ) are calculated by equation 11 and rounded up to nearest integer.

$$Nbr_{Hts} = \frac{Power_{Req.}}{Power_{Hts}} \quad (11)$$

where  $Power_{Req.}$  = Total power needed to increase temperature of the air volume beneath the poured concrete slab.  $Power_{Hts}$  = Power capacity of infrared heater (W). The term  $Power_{Req.}$  is calculated according to equation 12.

$$Power_{Req.} = \frac{Vol \times IsolF \times \Delta temp \times 4,18}{3600} \quad (12)$$

where  $Vol$  = Air volume of the floor space beneath the concrete slab (m<sup>3</sup>).  $IsolF$  = Isolation factor describing the degree of insulation and air tightness of the external walls that enclose the floor space beneath the concrete slab. Typical values for  $IsolF$  are given in (Cramo 2014);  $\Delta temp$  = difference in temperature between inside (floor space beneath concrete slab) and outside temperature (°C). Equations 10-12 are based on a calculation tool originally developed by (Lorentzon and Larsson 2010). The calculated variable  $Power_{Req.}$  was also validated against the input value (100 W/m<sup>2</sup>) used to simulate the infrared heaters according to curing strategy C described in chapter 6.

## 7.7 Validation of model inputs and logical behavior

Validation concerns both quality control of input data as well as methods for ensuring the internal quality of the simulation model (Sargent 2013). The model inputs consist of project and process data; weather statistics; formwork removal times; cost and carbon emissions data. Validation of these input data were done as an integrated part of data analysis described in

previous sections, e.g. project and process data (section 4), weather statistics (section 5), formwork removal times (section 6), and cost and carbon emission data (section 7.5-7.6).

Validation of the simulation model involved detailed studies of underlying logical descriptions and comparisons with documented workflow according to figure A.1 in appendix A. The computerized process model was then closely examined in terms of logical behaviour. Critical parts of the model were examined in detail using ExtendSim's animation functionalities. Simulation output statistics were also analysed in order to verify the algorithms describing the effects of weather on work task productivity as well as formwork removal times. The sequence of execution of work tasks and the dynamic use of resources were also analysed in order to ensure that the model operates as expected. As a final control, project and process data captured in field study A was used to test the model. More specifically, the floor cycle times of 14 days were selected as a main indicator for validation purpose. Floor cycle times are relatively easy to measure and are commonly used by contractors for planning and control purposes. Data regarding actual resource setup, workload quantities, and activity durations was used as inputs to the model. The model was then run under ideal conditions (no impact of weather) since it was reported that the project has been executed under favourable weather conditions without suffering any delays due to adverse weather conditions. It was concluded that the model was capable of reproducing the workflow observed at the building site and with desired floor cycle times of 14 days given the same set of model inputs as were documented from the real project.

## 8. Design of simulation experiments

The purpose of the simulation experiment was to demonstrate the model in order to study the effect of weather on both work task productivity as well as formwork removal time. Again, field project A was used as a basis for the simulation experiment. Example of input data used for the simulation of field study A are provided in tables A.4 to A.7. (appendix). To study the effect of weather conditions due to geographical and seasons variations, three different geographical locations and two seasons were considered. To study the effect of using concrete types with reduced carbon emissions, five different configurations of concrete types were simulated based on concrete mixtures described in section 6.3.2. The configuration of concrete types are denoted in bold text below.

- **STD:** Standard concrete mixtures are used in walls (WSTD) and in slabs (SSTD).
- **WS-10:** Concrete mixtures with reduced carbon emissions by 10% (compared to standard mixtures) are used in walls (W10) and slabs (S10).
- **WS-25:** Concrete mixtures with reduced carbon emissions by 25% (compared to standard) are used in walls (W25) and slabs (S25). It should be noted that this configuration is not suitable in floor slabs if requirements related to a quick drying out of concrete have to be fulfilled.
- **W25-SSTD:** Concrete with reduced CO<sub>2</sub> emissions by 25% are used in walls (W25) whereas standard concrete are used in slabs (SSTD).
- **W25-S10:** Concrete with reduced CO<sub>2</sub> emissions by 25% are used in walls (W25) whereas climate improved concrete by 10% are used in slabs (S10).

Finally, in order to study the effectiveness in different methods for shielding concrete against weather, three different curing strategies (A-C) according to table 5 were also included. The

overall matrix for the simulated scenarios are presented in table 9. In total, 150 scenarios were simulated.

**Table 9.** Simulation experiments matrix.

<b>Location (city)</b>	<b>Weather condition</b>	<b>Season for construction</b>	<b>Concrete configurations</b>	<b>Curing strategy</b>
Stockholm	Normal/Warm Cold	Winter/Autumn	STD/WS-10/WS-25/ W25-SSTD/W25-S10	A/B/C
Malmö	Normal	Winter/Autumn	STD/WS-10/WS-25/ W25-SSTD/W25-S10	A/B/C
Umeå	Normal	Winter/Autumn	STD/WS-10/WS-25/ W25-SSTD/W25-S10	A/B/C

## 9. Results

### 9.1 Normal weather conditions

In figure 12, simulated scenarios are presented (diagrams a to f). In general, the diagrams show the simulated duration, cost and carbon emissions for concrete framework construction. The simulated results are relative to a reference scenario which has been simulated in an ideal mode where the effect of weather on work task productivity as well as on concrete curing has been neglected. This reference corresponds to the construction duration reported in field project A where the project was carried out without any disturbances related to weather. Accordingly, the y-axis presents the relative effect on duration (time), cost and carbon emissions as described in sections 7.1-7.6. The reference scenario (with no effect of weather) is set to 1 for all indicators. The x-axis denotes the curing strategy (A, B and C) together with combinations of concrete types (WS-STD, WS-10 etc.). In cases where freezing of concrete occurs due to adverse weather conditions in combination with unfavorable selection of concrete types and curing measures, the model automatically stops and outputs an error-message indicating where in the process the model has stopped. As an example, this is illustrated in diagram b (figure 12) by terms as “Freezing, walls F1” meaning that freezing occurs during concrete curing of walls at floor level 1. The model also outputs error message if concrete temperature becomes too high ( $T > 60$  °C) since high temperatures may reduce the final compression strength. Simulated scenarios for autumn and winter seasons are presented in diagrams for different geographical locations; Malmö (diagram a and b), Stockholm (c and d), and Umeå (e and f).

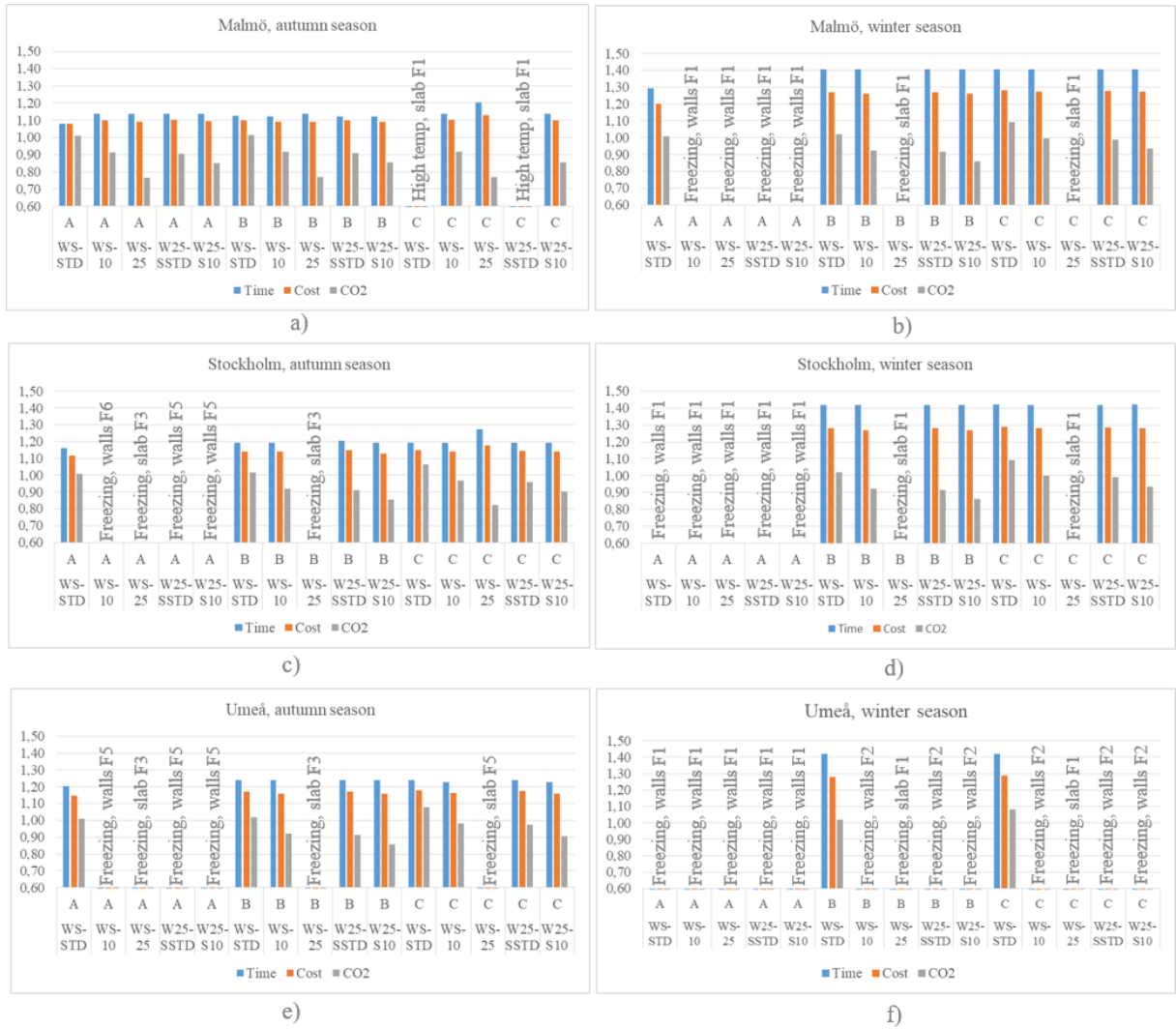

**Fig. 12.** Simulated time, cost and CO<sub>2</sub> emissions for Malmö, Stockholm, and Umeå for autumn and winter periods.

Referring to diagram a, the effect of weather during the autumn season typical for Malmö results in increased construction time by 8-20% compared to reference scenario. Costs are increased by 8-13%. Depending on the type of concrete used, carbon emissions are reduced by up to 23%. The construction duration is more or less the same regardless of the choice of concrete type and curing method. However, problems with high temperatures in slabs occurs when using curing method C and standard concrete mixture (WS-STD and W25-SSSTD). The effect of high concrete temperatures may also result in delayed formwork removal. This occurs when using WS-25 in combination with curing method C. Accordingly, curing method C is not suitable for use during autumn season. In diagram b, corresponding results for the winter season are presented. Here, the effect of weather on concrete types and the selection of curing strategy is more obvious. Early freezing occurs for all concrete types with reduced amount of Portland clinker when curing method A is used. However, methods B and C are both capable of shielding concrete against cold weather except for the case when concrete configuration WS-25 is used. For the cases when early freezing is not occurring, WS-STD and curing method A has the shortest duration (about 1.3 compared to reference). For B and C, construction duration is increased to 1.41 due to the additional work needed to employ the measures involved in these two curing strategies. The increase in duration for curing methods B and C compared to A

depends on increased time due to extra winter protection measures that are included in methods B and C but not in A. Especially winter preparations for walls are more likely to extend duration since these are on the critical line. The costs increase by 20-28% and carbon emissions are reduced by up to 14%.

The effect of weather in Stockholm during the autumn season is more significant compared to Malmö. In diagram c, it can be seen that curing strategy A is only capable of shielding the standard concrete configuration (WS-STD) against early freezing. Here, freezing occurs at higher floor levels, almost at the end of the construction project when colder weather conditions are more likely to occur. Also the working altitude may come into play since the wind chill effect is higher at higher altitudes. Construction durations are increased by 16- 27% compared to the reference case. Note that also here, a delayed formwork removal occurs for WS-25 and curing strategy C. Costs are increased by 12-18% and carbon emissions are reduced by up to 18%. In diagram d, simulation results for Stockholm during winter conditions are presented. As seen in figure 12, early freezing occurs for all cases involving curing strategy A. Also here, curing strategies B and C are capable of protecting all concrete types against freezing except for WS-25. For those cases where freezing not occur, construction durations are increased by 42% compared to reference. Costs are increased by almost 30% whereas carbon emissions are reduced by up to 14% depending on concrete type and curing strategy.

For Umeå, the effect of weather during the autumn period is shown in diagram e. As seen, early freezing occurs during the autumn period in more or less the same extent as was the case for Stockholm. The difference, however, is that freezing occurs somewhat earlier (at lower floors) for some scenarios as well as for concrete configuration WS-25 when curing method C is used. For cases where freezing do not occur, the construction time increases by 20-24% compared to the reference scenario. Costs are increased by 15-18% and maximum decrease in CO<sub>2</sub> emissions is 14%. During the winter season, the effect of colder weather in Umeå is more obvious compared to the other two geographical locations (diagram f). Here, it is only when standard concrete (WS-STD) in combination with curing method B and C that earlier freezing is avoided.

Comparing the results for Malmö, Stockholm, and Umeå during the winter season, it can be seen that there are no difference in duration for scenarios where no freezing occurs. This is explained by the fact that the extra work associated with winter protection measures are more important reason for an extended construction duration compared with the effects on duration as a result of lower work task productivity or a slower concrete curing process. The fact that winter protection measures are triggered in the model when temperature falls below zero degrees, the climate difference between Malmö, Stockholm, and Umeå has less impact when curing methods are employed. In addition, execution of winter preparation measures employed to walls are more likely to extend duration since these are on the critical time-line. Winter preparation measures employed on concrete slabs are executed in parallel to other work tasks and do not influence total lead time in the same way. The fact that slab activities contains more time buffers also explains why there is no difference in duration between curing method B and C. The time buffers between slab activities absorb delays caused by the additional work belonging to curing method C. However, the cost for method C is somewhat higher due to the use of external infrared heaters.

In table 10, minimum and maximum effects on time, cost and CO<sub>2</sub> emissions are presented for three locations (Malmö, Stockholm, and Umeå) and two seasons (autumn and winter). In

addition, time buffer values according to section 7.4 are also presented. All values for time, cost and CO<sub>2</sub> are normalized based on the reference case in where the effects of weather are neglected. For instance, the minimum time for Malmö during autumn season is equal to 1.08. Accordingly, the minimum effect of weather for this scenario is 8% increase in construction time related to the reference case. Note that the BuffTime values are given in days with no normalization to the reference case.

As seen in table 10, construction time is at minimum increased by 8% (1.08) compared to the reference case. This occurs in Malmö during the autumn season. The maximum increase is 42% (1.42) and occurs during the winter season for all three locations. Costs increase by 8-29% where the lowest increase refers to Malmö during the autumn season and the highest increase refers to both Stockholm and Umeå during winter season. Carbon emissions depends on the actual selection of concrete and curing strategy, geographical location, and the season for construction. At the most, carbon emissions are reduced by 23% (0.77) compared to reference and occurs for Malmö during the autumn season. Carbon emissions are increased at the most by 9% (1.09) during winter season for all locations. BuffTime values vary significantly during the autumn seasons for Malmö and Stockholm. The variation in BuffTime is much lower during winter season. Lowest BuffTime is equal to 0.2 days whereas highest BuffTime is almost 9 days (8.9).

**Table 10.** Summary of max and min values for time, cost, CO<sub>2</sub>, and BuffTime based on season and geographical location.

Location and season	Time		Cost		CO <sub>2</sub>		BuffTime (days)	
	Min	Max	Min	Max	Min	Max	Min	Max
<b>Malmö</b>								
Autumn	1.08	1.20	1.08	1.13	0.77	1.01	0.8	6.7
Winter	1.29	1.41	1.20	1.28	0.86	1.09	7.4	8.9
<b>Stockholm</b>								
Autumn	1.16	1.27	1.12	1.18	0.82	1.06	0.2	7.0
Winter	1.42	1.42	1.27	1.29	0.86	1.09	7.8	8.8
<b>Umeå</b>								
Autumn	1.20	1.24	1.15	1.18	0.86	1.08	6.5	7.2
Winter	1.42	1.42	1.28	1.29	1.02	1.09	6.9	7.5

As shown in figure 12, early freezing seems to be a bigger problem for the selected concrete types and curing methods than delayed formwork removal, especially during winter season. It is also obvious that early freezing is dependent on the combination of concrete and curing strategy. Accordingly, table 11 outlines what combinations of concrete types and curing methods that result in risk of early freezing or not for a given location and season. Red-marked cells in table denoted with “yes” means that actual combination of concrete and curing method leads to risk of early freezing. Cells denoted with “no” indicate no risk of early freezing. It is obvious that the introduction of climate-improved concrete requires more extensive measures in order to shield concrete against early freezing compared to traditional concrete types. For instance, considering northern located construction projects (e.g. Umeå) during winter seasons, even more extensive curing measures are needed compared to what have been studied in this report. Moreover, the concrete configuration with lowest climate impact is only possible to employ under a few circumstances, e.g. autumn season in Malmö or in Stockholm when employing curing method C.

**Table 11.** Risk of early freezing (cells denoted “yes”) for different concrete types and curing methods.

Location	Curing strategy	Concrete configuration									
		Autumn					Winter				
		WS-STD	WS-10	WS-25	W25-SSTD	W25-S10	WS-STD	WS-10	WS-25	W25-SSTD	W25-S10
Malmö	A	no	no	no	no	no	no	yes	yes	yes	yes
	B	no	no	no	no	no	no	no	yes	no	no
	C	no*	no	no	no	no	no	no	yes	no	no
Stockholm	A	no	yes	yes	yes	yes	yes	yes	yes	yes	yes
	B	no	no	yes	no	no	no	no	yes	no	no
	C	no	no	no	no	no	no	no	yes	no	no
Umeå	A	no	yes	yes	yes	yes	yes	yes	yes	yes	yes
	B	no	no	yes	no	no	no	yes	yes	yes	yes
	C	no	no	yes	no	no	no	yes	yes	yes	yes

\*) high curing temperature

## 9.2 Unusual weather conditions

In table 12, the effects of warmer and colder weather conditions for Stockholm are shown. Compared to normal weather, warmer conditions result in less impact on construction time and cost during both autumn and winter season. It also facilitates increased reductions of carbon emissions. On the other hand, colder weather result in increased time, cost, and CO<sub>2</sub> emissions during the autumn season compared to normal weather. However, during winter season the effect of cold weather is almost the same as normal weather. The effects on early freezing as a result of warmer and colder weather conditions for Stockholm are presented in table 13. Here, it can be seen that warmer weather enhances the possibilities to use climate-improved concrete, especially during autumn season. As expected, the effect of cold weather increases the risk of early freezing when using climate-improved concrete compared with normal weather conditions.

**Table 12.** Max and min values regarding time, cost, CO<sub>2</sub>, and BuffTime for different weather types for the case of Stockholm.

Season	Time		Cost		CO <sub>2</sub>		BuffTime (days)	
	Min	Max	Min	Max	Min	Max	Min	Max
Autumn (normal)	1.16	1.27	1.12	1.18	0.82	1.06	0.2	7.0
Winter (normal)	1.42	1.42	1.27	1.29	0.86	1.09	7.8	8.8
Autumn (warm)	1.11	1.19	1.09	1.13	0.77	1.03	0.5	6.5
Winter (warm)	1.27	1.31	1.19	1.21	0.80	1.05	0.5	8.0
Autumn (cold)	1.26	1.37	1.18	1.25	0.92	1.08	7.4	8.5
Winter (cold)	1.42	1.42	1.27	1.29	0.92	1.09	7.9	8.2

**Table 13.** Effect of unusual weather related to the risk of early freezing for the case of Stockholm.

Weather condition	Curing strategy	Concrete configuration									
		Autumn					Winter				
		WS-STD	WS-10	WS-25	W25-SSTD	W25-S10	WS-STD	WS-10	WS-25	W25-SSTD	W25-S10
Normal	A	no	yes	yes	yes	yes	yes	yes	yes	yes	yes
	B	no	no	yes	no	no	no	no	yes	no	no
	C	no	no	no	no	no	no	no	yes	no	no
Warm	A	no	no	no	no	no	yes	yes	yes	yes	yes
	B	no	no	no	no	no	no	no	yes	no	no
	C	no	no	no	no	no	no	no	no	no	no
Cold	A	yes	yes	yes	yes	yes	yes	yes	yes	yes	yes
	B	no	no	yes	yes	yes	no	no	yes	yes	yes
	C	no	no	yes	no	no	no	no	yes	yes	yes

### 9.3 Selection of optimal strategy

Combinations of concrete types and curing strategies that result in shortest time (duration), lowest cost, and/or lowest carbon emissions are presented in table 14 for each location and season.

**Table 14.** Most favourable combination of concrete configuration and curing strategy in terms of time, cost and CO<sub>2</sub> emissions.

Geographic location	Autumn		Winter	
	Value	CC: Concrete config. (CS: Curing strategy)	Value	CC: Concrete config. (CS: Curing strategy)
<b>Malmö</b>				
Time (min)	1.08	CC: WS-STD (CS: A)	1.29	CC: WS-STD (CS: A)
Cost (min)	1.08	CC: WS-STD (CS: A)	1.20	CC: WS-STD (CS: A)
CO <sub>2</sub> (min)	0.77	CC: WS-25 (CS: A, B, C)	0.86	CC: W25-S10 (CS: B)
<b>Stockholm</b>				
Time (min)	1.16	CC: WS-STD (CS: A)	1.42	CC: WS-STD (CS: B, C) CC: WS-10 (CS: B, C) CC: W25-SSTD (CS: B, C) CC: W25-S10 (CS: B, C)
Cost (min)	1.12	CC: WS-STD (CS: A)	1.27	CC: WS-10 (CS: B) CC: W25-S10 (CS: B)
CO <sub>2</sub> (min)	0.82	CC: WS-25 (CS: C)	0.86	CC: W25-S10 (CS: B)
<b>Umeå</b>				
Time (min)	1.20	CC: WS-STD (CS: A)	1.42	CC: WS-STD (CS: B, C)
Cost (min)	1.15	CC: WS-STD (CS: A)	1.28	CC: WS-STD (CS: B)
CO <sub>2</sub> (min)	0.86	CC: W25-S10 (CS: B)	1.02	CC: WS-STD (CS: B)

As seen, the combination that includes standard concrete types (WS-STD) and curing strategy A results in both shortest time and lowest cost for all three locations during the autumn period. However, considering lowest carbon-emissions, combinations including concrete configurations WS-25 and W25-S10 combined with curing methods A, B or C are preferable. The actual combination of concrete type and curing method depends on the geographical location and season. For instance, the most climate-improved concrete type W25 works for all curing methods in Malmö during autumn but requires method C in Stockholm. In Umeå, it is necessary to select a concrete configuration with somewhat higher climate impact (W25-S10) in order to avoid early freezing during autumn season. However, for this concrete configuration



curing method B is sufficient. Regarding the winter period in Malmö, standard concrete types (WS-STD) combined with curing method A yields shortest duration and lowest cost. However, if lowest carbon emissions are top priority, the combination including W25-S10 should be selected. For Stockholm, four different concrete configurations (WS-STD, WS-10, W25-STD, W25-S10) combined with either curing method B or C yield shortest duration. Considering lowest cost, two combinations of concrete types and one curing strategy are preferable, namely WS-10 and W25-S10 together with curing strategy B. In addition, the combination including W25-S10 and curing method B also yields lowest CO<sub>2</sub> emissions. Accordingly, this combination yields the best solution for all three performance indicators. For Umeå, standard concrete configuration WS-STD combined with curing methods B or C results in shortest duration in winter season. Considering lowest cost and carbon emissions, standard concrete configuration should be combined with curing methods B only.

## 10. Discussion and conclusions

### 10.1 Model for considering effects of weather on both work tasks and concrete curing

Compared to other simulation models reported in previous research (Moselhi *et al.* 1997; Jung *et al.* 2016), the model described in this article considers the impact of weather on both physical working processes and material-related processes. The model is a further development of previous research presented in (Larsson 2019) and in Larsson and Rudberg (2019). The model integrates existing knowledge from two different research fields, enabling a comprehensive description of the weather's impact on in-situ concrete. The model can be used to systematically analyse the production system and its sensitivity to different weather conditions based on, for example, season and geographical location. Various combinations of concrete types (including climate-improved concrete) and curing methods can be simulated for various weather conditions. This is especially interesting in order to find optimal combinations of climate-improved concrete types and curing methods for different geographical areas and seasons. Accordingly, the model could be a valuable tool when defining production technology concepts based on different requirements related to construction duration, cost and climate impact. The model could also be useful for short-term planning, e.g. to verify the construction schedule for the next week based on updated weather forecast. However, this requires that the model is made more user-friendly, e.g. by enabling automated import of input data.

### 10.2 Implications of climate-improved concrete and need for curing methods

The results presented in section 9 indicate that weather is an important factor to account for during construction of concrete frameworks, especially in periods with colder weather. In general, three types of weather-related effects have been found; 1) Loss in labour productivity since construction workers typically work more slowly in poor weather conditions or specific work tasks cannot be carried out (work stoppage); 2) Cold temperatures and windy conditions slows down the concrete curing process. Poor selection of concrete type and curing method can result in problems related to early freezing and/or delays in formwork removal; 3) Curing methods themselves imply additional work tasks that may extend duration of cycle times. The results indicate that effects 1-3 result in that construction time is extended by 8-42% compared to when weather is not accounted for. The costs increase by 8-29% and are a combination of extended construction time and additional measures to protect the concrete during curing. The

variation in results depend on the choice of concrete types, curing methods, and differences in weather depending on the season for construction and on the geographical location of the project. The results clearly show on differences between autumn and winter seasons. Especially, early freezing becomes more problematic during winter compared to the autumn period. In cases where early freezing do not occur, construction time is extended by 17-25% during winter compared to autumn.

The results also indicate reductions in carbon emissions by up to 23% when climate-improved concrete types are used. However, it is also obvious that weather conditions become even more important when climate-improved concrete is used as this is more sensitive to colder weather. The results reveal that the risk associated with early freezing increases when climate-improved concrete is used. Accordingly, selection of such concrete types must be combined with sufficient curing measures that are capable of shielding concrete for actual weather conditions expected during time of construction. In general, warmer weather conditions are more advantageous for implementation of climate-improved concrete types. For example, early freezing occurs in 50% of all scenarios containing climate-improved concrete in Malmö whereas freezing occurs for all scenarios in Umeå due to colder weather conditions. In addition, change in climate conditions can also affect the possibilities to use climate-improved concrete. Considering Stockholm for example, it was shown that 79% of all scenarios containing climate-improved concrete can withstand early freezing when the climate corresponds to warm weather conditions (refer to table 13). This can be compared with only 54% for normal weather conditions. The effect is obviously the opposite in a colder climate where only 17% of all scenarios can withstand early freezing.

It is also clear that the choice of curing methods become more important when climate-improved concrete is used. For example, more extensive curing measures than those included in methods B and C in this study are required to enable the use of e.g. a 25 percentage-reduced concrete (WS-25) in winter periods. Considering the design of the studied production system, lead-time of concrete wall cycles are important for the lead-time of the overall construction cycle. The work cycle is sensitive to disruptions such as need for extra winter works. Any delays in work tasks or in concrete curing process may force the whole construction cycle out of sequence with delays propagating into downstream activities. Therefore, upscaling of climate-improved concrete requires a careful analysis and evaluation of curing methods in advance of construction. Project planning must also account for the need for additional resources that a specific curing method requires.

As mentioned earlier, delayed formwork removal has been found in this study to be a minor problem compared to early freezing. The high BuffTime-values show that, in most cases, curing of concrete is not crucial when horizontal formwork can be removed. Instead, it is the completion time of preceding work tasks that determine when table forms can be removed. The rapid strength development in concrete floors enables substantially shorter construction cycles, up to almost 9 days. But in order to take advantage of such shortened formwork removal times, the speed of the overall working process must be accelerated. If it's not possible to speed up the working process, it might be more advantageous to select concrete types with slower strength development combined with suitable curing methods that lead to formwork removal times that are better adjusted to the overall construction cycle. This can lead to reduced project costs and environmental impact without extending construction duration. Another possibility is to adopt new ideas of how to design concrete production systems, e.g. by changing the work

schedule enabling construction cycles that are more aligned with extended formwork removal times. However, the practical implications of such changes must be further explored.

The BuffTime value as such can be used as an indicator showing the remaining capacity in terms of formwork removal time that a production setup possess. This is useful in order to evaluate if other configurations of concrete types are possible in order to reduce carbon emissions without extending construction duration and by that also increasing construction cost.

Since manufacturing of cement is responsible for about 8% of the global carbon emissions, cement and concrete industries are devoted to radically reduce their emissions. Therefore, a broader use of climate-improved concrete types are necessary in most countries. As a consequence, the need for deeper knowledge about how different weather conditions affect construction time and cost are needed and what curing measures that are suitable to enable large-scale introduction of climate-improved concrete types regardless of season and geographic location. As shown by results in table 14, there exist no solution were all construction performance indicators are minimized simultaneously. Therefore, selecting an optimal solution must be evaluated against project or company priorities in terms of time, cost and carbon emissions.

Environmental costs related to carbon emissions have rarely been included in cost estimations within the construction industry. However, during recent years, the environmental cost have more often been taken into consideration, e.g. in life cycle cost models for making socio-economical estimations of large infrastructure projects ([Garberg et al. 2019](#)). In future, environmental costs could also be integrated when making production cost estimations on a routinely basis. This would facilitate a total cost analysis of production methods where the environmental benefits are highlighted and by that enabling for selection of methods that are favourable from an environmental perspective.

### 10.3 Research limitations and need for further research

The study presented in this article has focused on the in-situ concrete framework construction phase, specifically considering the effects of weather on work task productivity and curing of concrete to allow formwork removal. Other important aspects such as drying-out of concrete floors in order to enable flooring activities have not explicitly been considered. Moreover, the results are based on weather conditions typical for a Swedish (Scandinavian) climate. The results are also based on mathematical relationships describing the influence of weather factors on work task productivity reported in previous research projects. Since these relationships are typically valid for general construction works it would be an interesting future research to collect more information and data related to specific concrete work tasks in order to verify existing weather-productivity relationships or developing new ones. Moreover, the results presented in this report are based on deterministic input values, but most construction projects are characterized by uncertainty. Further research should therefore aim at establishing the stochastic characteristics of data describing the uncertainty related to weather effects on both manual and material processes. Such information could then be used as random inputs to the simulation model presented in this report.

It should also be emphasized that the results presented in this study are limited to a few combinations of climate-reduced concrete types and curing methods. Indeed, it is possible to use concrete mixtures that contains even less Portland clinker enabling further reductions in

carbon emissions. Similarly, it is strongly advisable to test more extensive curing measures as were studied here, in order to enable the use of such climate-improved concrete mixtures also during winter periods and regardless of geographical location. It should also be mentioned that the risk of freezing is based on simulations using a specific tool (PPB). The results are therefore dependent on the actual tool's ability to predict early freezing. The simulation tool reports problems due to early freezing even for a very limited part of the concrete structure. This approach may be considered to be rather strict from a practical viewpoint but is important since early freezing may cause permanent damages.

The model is limited to describing the on-site construction process of in-situ concrete frameworks. However, the model can be adjusted so that other production systems can be simulated in addition. Moreover, formwork removal times are only valid for a specific concrete wall and slab structure and concrete types that are typically used in Sweden. However, it is easy to feed the model with simulated formwork removal times valid for other concrete structures containing other concrete mixtures. In cases where high-quality predictions of formwork removal times are needed, it is strongly recommended to perform detailed analysis of formwork removal times. For this purpose, as also pointed out by [Brooks \*et al.\* \(2007\)](#), having access to maturity properties for specific concrete mixtures is crucial. Moreover, the use of wireless sensor systems during construction to monitor concrete temperatures and strength development are important tools in order to enable an effective and safe removal of formwork ([Alizadeh 2019](#)). In addition, the measurements are also important as real input to validate special-purpose simulation tools for making predictions of concrete strength but also for validating the functional performance of new concrete mixtures. However, as pointed out in section 4.3.2, isolated sensor data are not enough. It must also be supplemented with other information such as geometries of concrete structure, concrete mixture, type of curing measures etc.

Finally, further research should also be directed to the implications on employing climate-improved concrete types on a larger scale in construction projects. For instance, exploring the necessary operational adjustments of the production system. To facilitate a broader implementation of climate-improved concrete types, further research should also focus on means to integrate environmental costs in cost estimation models.

#### 10.4 Conclusions

Unfavourable weather conditions reduce construction productivity in general. Therefore, awareness and knowledge about how weather affects construction works are essential during planning and execution of construction projects. Concrete construction methods are affected by weather in at least three ways; 1) manual and machine-assisted work tasks are either hindered or the working pace is reduced; 2) curing of concrete may be subjected to early freezing or may lead to delayed formwork removal; 3) measures to shield concrete curing against weather may imply additional work tasks and need for extra resources affecting the overall productivity. The results presented in this report indicate that these effects (1-3) collectively extend construction duration by 8-42% due to various weather conditions depending on season and location of the project. The results also highlight potential reductions in carbon footprint of concrete frameworks by employing climate-improved concrete. However, weather conditions become even more important to consider when using these concrete types since they are generally more sensitive to certain weather conditions, e.g. cold temperature in combination with windy conditions. The simulation-based approach described in this report provides new means to make systematic and holistic analysis of how varying weather conditions influence concrete

construction works in terms of time, cost, and climate impact. In addition, the simulation model enables to study effects of employing climatic-reduced concrete types and what measures that are necessary to apply in order to make such concrete mixtures resilient to weather regardless of the season or location of the construction.

## References

- Aalborg Portland (2018), *IT Tools – din genvej til online produktstyring og kvalitetssikring*. website: <https://www.aalborgportland.dk/vidensbase/it-tools/>. (in Danish).
- Alizadeh, Aali R.(2019), *Concrete Testing Goes Wireless Wireless sensors and smart phone apps make maturity testing more efficient than ever*, Construction Specifier, May 2019.
- Amerian Concrete Institute (2019), *Report on Methods for Estimating In-Place Concrete Strength*, ACI Committe 228, Report ACI 228.1R-19, pp. 48, Farmington Hills, MI, US. Bagheri-Zadeh, S., Kim, H., Hounsell, S., Wood, C.R., Soleymani, H. and King, M. (2007), "Field Study of Concrete Maturity Methodology in Cold Weather", *Journal of Construction Engineering and Management*, Vol. 133, No. 11, pp. 827-835.
- Ballesteros-Perez, P., del Campo-Hitschfeld, M.L., Gonzalez-Naranjo, M.A. and Gonzalez-Cruz, M.C. (2015), "Climate and construction delays: case study in Chile", *Engineering, Construction and Architectural Management*, Vol. 22, No. 6, pp. 596-621.
- Benaicha, M., Burtschell, Y. and Alaoui, A.H. (2016), "Prediction of compressive strength at early age of concrete – Application of maturity", *Journal of Building Engineering*, Vol. 6, pp. 119-125.
- Birgisson, K.R. (2009), *Discrete-event simulations of construction related production systems*, Thesis Report 5173, Div. Structural Engineering, Lund University, pp. 101.
- Brooks, A.G., Schindler, A.K. and Barnes, R.W. (2007), "Maturity Method Evaluated for Various Cementitious Materials", *Journal of Materials in Civil Engineering*, Vol. 19, No. 12, pp. 1017-1025.
- Carino, N.J. and Lew, H.S. (2001), "The Maturity Method: From Theory to Application", *Reprinted from Proceedings of the 2001 Structures Congress & Exposition, May 21-23 2001*, Washington D.C., ASCE, Reston, Virginia, Editor: P. Chang, pp. 19.
- Cementa AB (2007), *Uppvärm betong – säkrare, snabbare, billigare*, p. 9, Cementa AB (in Swedish). Cementa AB (2014), *Betonggjutning i kall väderlek* Cementa AB (in Swedish).
- Cementa AB (2018), *Hett II (Software tool for estimation of temperature and strength in concrete structures)*, website: <https://www.cementa.se/sv/prognosverktyg-hett-II> (in Swedish).
- CEN (2012), *Sustainability of construction works - Environmental product declarations - Core rules for the product category of construction products*, EN 15804:2012+A2:2019, website: <https://standards.cen.eu/index.html>.
- Cramo (2014), *Cramo Hyresguide*, Cramo, p. 62 (in Swedish).
- Fjellström, P. (2013), *Measurement and modelling of young concrete properties*. Lic. Thesis, p. 200, ISBN 978-91-7439-644-7, Luleå Technical University, Luleå, Sweden.
- Garberg, B., Bengtsson, M., and Martini, V. (2019), *Åtgärder för ökad andel godstransporter på järnväg och med fartyg. Redovisning av regeringsuppdrag*. Trafikverket Rapport nr: 2019:140, p. 99, Sweden (in Swedish).
- Hassi, J. (2002), *Handbok för kallt arbete*, p. 112, (In Swedish), Arbetslivsinstitutet, Stockholm, Sweden.
- Holmér, I. (1994), "Cold stress: Part I - Guidelines for the practitioner", *International Journal of Industrial Ergonomics*, Vol. 14, No. 1-2, pp. 139-149.

- Illingworth, J.R. (2000), *Construction Methods and Planning*, 2nd edition ed., Spon Press, London, U.K.
- ISO (2006), *Environmental management – Life cycle assessment – Requirements and guidelines*, ISO-standard 14044:2006, Reviewed 2016, p. 46, ISO/TC 207/SC5, website: <https://www.iso.org/standard/38498.html>.
- Jonasson, J. (1985), *Slipform construction: calculations for assessing protection against early freezing*, Cement- och betonginst., Report 84:4, p.70, Stockholm, Sweden.
- Jung, M., Park, M., Lee, H.-S., and Kim, H. (2016), "Weather-delay simulation model based on vertical weather profile for high-rise building construction", *Journal of Construction Engineering and Management*, Vol. 142, No. 6.
- Koehn, E., Brown, G., Koehn, E. and Brown, G. (1985), "Climate Effects on Construction", *Journal of Construction Engineering and Management*, Vol. 111, No. 2, pp. 129.
- Krahl, D. (2003), "Extend: an interactive simulation tool", "Extend: an interactive simulation tool", IEEE, New Orleans, LA., 7-10 December, pp. 188.
- Larsson, R. and Rudberg, M. (2019), "Impact of Weather Conditions on in Situ Concrete Wall Operations Using a Simulation-Based Approach", *Journal of Construction Engineering and Management*, Vol. 145, No. 7.
- Larsson, R. (2019), "An Integrated Simulation-Based Methodology for Considering Weather Effects on Formwork Removal Times", *35th CIB W78 Conference, 1-3 October, 2018*, pp. pp. 41, Springer Int. Publishing, Cham, Switzerland.
- Ljungkrantz, C., Möller, G. and Petersons Nils (Eds.) (1992), *Betonghandbok - Arbetsutförande*, 2nd ed., AB Svensk Byggtjänst, (In Swedish), Solna, Sweden.
- Lorentzon, J. and Larsson, O. (2010), "An essay about the products available to heat construction sites and their required energy expenditure", *Master Thesis*, Karlstad University, p. 75, (in Swedish).
- Lothenbach, B., Scrivener, K. and Hooton, R.D. (2011), "Supplementary cementitious materials", *Cement and Concrete Research*, Vol. 41, No. 3, pp. 217-229.
- Lucko, G., Benjamin, P. C. and Madden, M. G. (2008), "Harnessing the power of simulation in the project management / decision support aspects of the construction industry", IEEE, Miami, FL, 7-10 december, pp. 2479.
- Mäkinen, T.M., Pääkkönen, T., Rintamäki, H., Palinkas, L.A., Leppluoto, J. and Hassi, J. (2005), "Manual performance in urban circumpolar subjects exposed to cold in the winter and summer", *Elsevier Ergonomics Book Series*, Vol. 3, pp. 193-197.
- Mayer, R.J., Menzel, C.P., Painter, M.K., deWitte, P.S., Blinn, T. and Perakath, B. (1995), *Information Integration for Concurrent Engineering (IICE) IDEF3 Process Description Capture Method Report*.
- Moselhi, O., Gong, D. and El-Rayes, K. (1997), "Estimating weather impact on the duration of construction activities", *Canadian Journal of Civil Engineering*, Vol. 24, No. 3, pp. 359-366.
- Moselhi, O. and Khan, Z. (2010), "Analysis of labour productivity of formwork operations in building construction", *Construction Innovation*, Vol. 10, No. 3, pp. 286-303.
- Noreng, K. (2005), *Værbeskyttet bygging med Weather Protection Systems (WPS)* Byggforsk, Rapport 119-2005, Oslo, Norway.
- Nurse, R.W. (1949), *Steam Curing of Concrete* 79-88. *Magazine of Concrete Research*, Vol. 1, No. 2, June 1949, pp.21-28.
- Sargent, R.G. (2013), "An introduction to verification and validation of simulation models", IEEE, Washington, DC., 8-11 December, pp. 321.



- Saul, A.G.A. (1951), "Principles underlying the steam curing of concrete at atmospheric pressure", *Magazine of Concrete Research*, Vol. 2, No. 6, pp. 127-140.
- SBUF (2015), *Produktionsplanering Betong (PPB), Software tool for estimation of temperature and strength in concrete structures*, website: <https://www.sbuf.se/ppb/>. (in Swedish).
- SCB (2020), *Faktorprisindex (FPI) för bostäder exkl. löneglidning och moms, 1968=100, efter hustyp och kostnadsslag. Månad 1975M01 - 2020M04*, Statistics Sweden, website: scb.se (in Swedish).
- SIS (2016), *Betong - Fordringar, egenskaper, tillverkning och överensstämmelse. Svensk Standard SS-EN 206:2013+A1:2016, Utgåva 1, Fastställd 2016-11-08, p. 112.*
- SMHI (2013), *Hur mäts snödjup?* Kunskapsbanken, Sveriges meteorologiska och hydrologiska institut. website: <https://www.smhi.se/kunskapsbanken/meteorologi/hur-mats-snodjup-1.27291> (in Swedish).
- Svensk Betong (2017), *EPD för betong, ID: NEPD-1295-419 to 1299-419*. Svensk Betong, (In Swedish), available at: [www.epd-norge.no](http://www.epd-norge.no).
- Svensk Betong (2019), *Klimatförbättrad betong*, (In Swedish), Svensk Betong, Stockholm, Sweden, website: [https://www.svenskbetong.se/images/pdf/klimatforbatttrad\\_betong\\_webb3.pdf](https://www.svenskbetong.se/images/pdf/klimatforbatttrad_betong_webb3.pdf) (in Swedish).
- Thomas, H. R. and Ellis Jr., R. D. (2009), "Fundamental principles of weather mitigation", *Practice Periodical on Structural Design and Construction*, Vol. 14, No. 1, pp. 29-35.
- Thomas, H.R., Riley, D.R. and Sanvido, V.E. (1999), "Loss of labour productivity due to delivery methods and weather", *Journal of Construction Engineering & Management*, Vol. 125, No. 1, pp. 39.
- Thomas, H.R. and Yiakoumis, I. (1987), "Factor Model of Construction Productivity", *Journal of Construction Engineering and Management*, Vol. 113, No. 4, pp. 623.
- Vema Venturi, AB. *Vema Distant*, website: [distant.vemaventuri.se](http://distant.vemaventuri.se) (in Swedish).
- Watson, T. (2004), *When the wind blows*, World Market Intelligence, London, UK.
- WebMet (2002), *The meteorological resource centre*, website: [http://www.webmet.com/met\\_monitoring/625.HTML](http://www.webmet.com/met_monitoring/625.HTML)





**Table A.1.** Formwork removal times for vertical formwork.

<b>Formwork removal times (vertical formwork)</b>										
Hours between end of concrete pour and formwork removal (concrete strength > 6 MPa*)										
Freezing constraint: Concrete strength > 5 MPa when air temp. < 0°C. Otherwise “error”.										
Concrete configuration	Curing strategy	Wind condition 0-6 m/s >6m/s	Air temperature (°C)							
			-25	-20	-15	-10	-5	0	5	10
SSTD	A	0-6	error	error	12.1	12.1	12.1	12.1	12.1	12.1
SSTD	A	>6	error	error	error	error	12.1	12.1	12.1	12.1
S10	A	0-6	error	error	error	12.1	12.1	12.1	12.1	12.1
S10	A	>6	error	error	error	error	error	12.1	12.1	12.1
S25	A	0-6	error	error	error	error	12.4	12.3	12.1	12.1
S25	A	>6	error	error	error	error	error	12.3	12.1	12.1
SSTD	B	0-6	12.1	12.1	12.1	12.1	12.1	12.1	12.1	12.1
SSTD	B	>6	error	12.1	12.1	12.1	12.1	12.1	12.1	12.1
S10	B	0-6	12.1	12.1	12.1	12.1	12.1	12.1	12.1	12.1
S10	B	>6	error	error	12.1	12.1	12.1	12.1	12.1	12.1
S25	B	0-6	error	12.1	12.1	12.1	12.1	12.1	12.1	12.1
S25	B	>6	error	error	error	12.1	12.1	12.1	12.1	12.1
SSTD	C	0-6	12.1	12.1	12.1	12.1	12.1	12.1	12.1	12.1
SSTD	C	>6	error	12.1	12.1	12.1	12.1	12.1	12.1	12.1
S10	C	0-6	12.1	12.1	12.1	12.1	12.1	12.1	12.1	12.1
S10	C	>6	error	error	12.1	12.1	12.1	12.1	12.1	12.1
S25	C	0-6	error	12.1	12.1	12.1	12.1	12.1	12.1	12.1
S25	C	>6	error	error	error	12.1	12.1	12.1	12.1	12.1

**Table A.2.** Formwork removal times for horizontal formwork.

<b>Formwork removal times (horizontal formwork)</b>										
Hours between end of concrete pour and formwork removal (concrete strength > 21 MPa*),										
Freezing constraint: Concrete strength > 5 MPa when air temp. < 0°C. Otherwise “error”.										
Concrete configuration	Curing strategy	Wind condition 0-6 m/s >6m/s	Air temperature (°C)							
			-25	-20	-15	-10	-5	0	5	10
SSTD	A	0-6	error	error	32.5	24.9	21.8	19.8	18	16.8
SSTD	A	>6	error	error	error	error	29.5	23	20	18
S10	A	0-6	error	error	error	33	26.8	23.8	22	20.8
S10	A	>6	error	error	error	error	61	29.5	24.4	22
S25	A	0-6	error	error	error	error	error	259	159	131
S25	A	>6	error	error	error	error	error	315	183	131
SSTD	B	0-6	error	error	21.8	19.3	17.8	16.5	15.5	14.5
SSTD	B	>6	error	error	error	30	22.3	19.3	17.3	15.8
S10	B	0-6	error	error	29	24.3	22	20.5	19.5	18.5
S10	B	>6	error	error	error	error	31	24	21.5	19.8
S25	B	0-6	error	error	error	error	error	251	167	147
S25	B	>6	error	error	error	error	error	299	175	131
SSTD	C	0-6	19.5	17.8	19.3	15.5	14.8	14	13.3	12.8
SSTD	C	>6	error	22.3	19.5	17.5	16.3	15	14	13.3
S10	C	0-6	24.3	22	20.5	19.5	18.8	18	17.5	17.5
S10	C	>6	error	31	24	21.8	20.3	19	18.3	17.5
S25	C	0-6	error	error	error	error	240	188	184	192
S25	C	>6	error	error	error	error	error	208	180	172

**Table A.3.** Overview of cost data used in simulation model. Denotations according to table 7.

<b>Cost item (cost/unit)</b>	<b>Cost</b>	<b>Sources</b> (primary in bold style, secondary in italic style)	<b>Factor Price Index<sup>1</sup></b>
<i>GSR</i> (EUR/day)	4 789	<ul style="list-style-type: none"> <li>• <b>Field project A (Site manager)</b></li> <li>• <i>Rental company cranes (2018)</i></li> <li>• <i>Price list rental company (2017)</i></li> <li>• <i>Report Ankaräng (2014)</i></li> <li>• <i>Report Stahl (2011)</i></li> <li>• <i>Report Eiderbrandt och Blomqvist (2010)</i></li> </ul>	FPI <sub>A</sub> , FPI <sub>B</sub> , FPI <sub>C</sub>
<i>FW<sub>walls</sub></i> (EUR/day)	195	<ul style="list-style-type: none"> <li>• <b>Formwork supplier, personal communication (2019)</b></li> <li>• <i>Report Dahlström (2012)</i></li> </ul>	FPI <sub>A</sub>
<i>FW<sub>slab</sub></i> (EUR/day)	409	<ul style="list-style-type: none"> <li>• <b>Formwork supplier, personal communication (2019)</b></li> <li>• <i>Report Dahlström (2012)</i></li> </ul>	FPI <sub>A</sub>
<i>CM<sub>walls</sub></i> (EUR/use, pour)	165-188 <sup>2</sup>	<ul style="list-style-type: none"> <li>• <b>Rental company (equipment for temporary heating), personal communication (2019)</b></li> <li>• <i>Report Linddal (2013)</i></li> <li>• <i>Report Lorentzon and Larsson (2010)</i></li> </ul>	FPI <sub>A</sub>
<i>CM<sub>slab</sub></i> (EUR/use, pour)	406-1 606 <sup>2</sup>	<ul style="list-style-type: none"> <li>• <b>Rental company (equipment for temporary heating), personal communication (2019)</b></li> <li>• <i>Report Linddal (2013)</i></li> <li>• <i>Report Lorentzon and Larsson (2010)</i></li> </ul>	FPI <sub>A</sub>
<i>CON<sub>walls</sub></i> (EUR/m <sup>3</sup> concrete)	204-210 <sup>3</sup>	<ul style="list-style-type: none"> <li>• <b>Concrete supplier, personal communication (2019)</b></li> <li>• <i>Concrete supplier, price list (2018)</i></li> <li>• <i>Cement supplier, personal communication (2017)</i></li> </ul>	FPI <sub>D</sub>
<i>CON<sub>slab</sub></i> (EUR/m <sup>3</sup> concrete)	221-234 <sup>3</sup>	<ul style="list-style-type: none"> <li>• <b>Concrete supplier, personal communication (2019)</b></li> <li>• <i>Concrete supplier, price list (2018)</i></li> <li>• <i>Cement supplier, personal communication (2017)</i></li> </ul>	FPI <sub>D</sub>

<sup>1)</sup> FPI<sub>A</sub>=Factor Price Index for machinery and equipment, FPI<sub>B</sub>=Factor Price Index for overhead costs, FPI<sub>C</sub>= Factor Price Index for labour and supervisors, FPI<sub>D</sub>=Factor Price Index for material. Source: Factor Price Index, SCB, <http://www.statistikdatabasen.scb.se>.

<sup>2)</sup> Variable cost depending on amount of curing measures related to selected curing strategy.

<sup>3)</sup> Variable cost depending on concrete type and degree of heated concrete (20-25°C).

**Table A.4.** Resource allocation strategy, productivity rates, weather factors and wind speed thresholds.

UOB	Activity name	Unit	Resource allocation <sup>1</sup>	Prod.rate (man-hours/unit)	Weather factor (wf) <sup>2</sup>	Wind speed threshold (m/s)
1	Prep. wall form <sup>3</sup>	Available formwork (m)	3A	0.50	Yes	n/a
2	Floor grinding	Concrete slab area (m <sup>2</sup> )	2B	0.03	yes	n/a
3	Erect formwork	Concrete wall area (m <sup>2</sup> )	2A-B+1I	0.10	yes	15
4	Install box outs	Concrete wall area (m <sup>2</sup> )	1A	0.02	yes	n/a
5	Ducts & cables	Concrete wall area (m <sup>2</sup> )	1E-G	0.04	yes	n/a
6	Install rebars	Quantity of rebars (kg)	1A+2B	0.02	yes	n/a
7	Closing formwork	Concrete wall area (m <sup>2</sup> )	2A-B+1I	0.10	yes	15
8	Winter prep. walls	Concrete wall area (m <sup>2</sup> )	1A	0.06	yes	n/a
9	Pour concrete	Concrete volume (m <sup>3</sup> )	2A-B+1I	0.30	yes	15
10	Concrete curing	n/a	n/a	n/a	n/a	n/a
11	Remove formwork	Concrete wall area (m <sup>2</sup> )	2A-B+1I	0.02	yes	15
12	Lift infill materials	Number of lifts (pcs)	2C+1I	0.17	yes	20
13	Move formwork	Formwork (m <sup>2</sup> )	2A-B+1I	0.01	yes	15
14	Surface repair	Concrete wall area (m <sup>2</sup> )	2B	0.10	no	n/a
15	Install table forms	Formwork area (m <sup>2</sup> )	2C+1D+1J	0.13	yes	14
16	Compl. formwork	Formwork area (m <sup>2</sup> )	2C+1D	0.35	yes	n/a
17	Safety inspection	Per floor	1H	1.0	No	n/a
18	Lift rebars, MEP	Number of lifts (pcs)	2D-G+1I	0.17	yes	20
19	Setting out (MEP)	Concrete slab area (m <sup>2</sup> )	1H	0.01	yes	n/a
20	Electrical outlets	Concrete slab area (m <sup>2</sup> )	2E	0.02	yes	n/a
21	Rebar btm, stirrups	Quantity of rebars (kg)	2D	0.02	yes	n/a
22	Inst. stair elements	Pieces of elements (pcs)	2C+1I	0.50	yes	14
23	Install balconies	Pieces of elements (pcs)	2C+1J	0.50	yes	14
24	Install columns	Pieces of elements (pcs)	2C+1I	0.50	yes	14
25	Pipes el. system	Concrete slab area (m <sup>2</sup> )	2E	0.06	yes	n/a
26	Ducts air systems	Concrete slab area (m <sup>2</sup> )	2G	0.09	yes	n/a
27	Pipes water/sew.	Concrete slab area (m <sup>2</sup> )	2F	0.09	yes	n/a
28	Lift rebars top	Number of lifts (pcs)	2D+1I	0.17	yes	20
29	Rebars top layer	Quantity of rebars (kg)	2D	0.02	yes	n/a
30	Box outs wetrooms	Number of units (pcs)	2C	0.50	yes	n/a
31	Winter prep. slab	Concrete slab area (m <sup>2</sup> )	2C+2D	0.02/0.10 <sup>4</sup>	yes	n/a
32	Inspection pouring	Per floor	1H	2.0	no	n/a
33	Pour concrete	Concrete volume (m <sup>3</sup> )	1C+2D+1K	0.20	yes	20
34	Concrete slab cover	Concrete slab area (m <sup>2</sup> )	2C+2D	0.02	no	n/a
35	Curing (grinding)	n/a	n/a	n/a	n/a	n/a
36	Curing(table form)	n/a	n/a	n/a	n/a	n/a
37	Process termination	n/a	n/a	n/a	n/a	n/a

- 1) A=carpenter walls; B=concreters walls; C=carpenter slab; D=concreters slab; E=Electrician; F=Plumber; G=Ventilation worker; H=Foreman; I=Tower crane; J=Mobile crane; K=Concrete pump
- 2) Yes=Weather function (temp, wind, prec) is applied on work tasks according to equation 3.
- 3) Only executed once, prior to start of erection of framework.
- 4) Depends on curing strategy. Lower value refers to curing strategy A and B whereas higher value refers to curing strategy C.

**Table A.5.** General input data for concrete walls.

Row no.	Building Id	Floor level	Height (m)	Wall phase no.	Wall no.	Wall length (m)	Wall area (m <sup>2</sup> )	Concrete volume (m <sup>3</sup> )	Rebar (kg)
1	1	1	21.0	1	1	3.9	9.8	1.5	98
2	1	1	21.0	1	2	3.9	9.8	1.5	98
3	1	1	21.0	1	3	5.3	13.3	2.9	133
4	1	1	21.0	1	4	2.6	6.5	1.4	65
5	1	1	21.0	1	5	4.3	10.8	2.4	108
...	...	...	...	...	...	...	...	...	...
148	1	6	34.5	5	1	10.2	25.5	5.6	255
149	1	6	34.5	5	2	1.9	4.8	1.0	48
150	1	6	34.5	5	3	1.9	4.8	1.0	48

**Table A.6.** General input data for concrete slabs.

Row no.	Build. Id	Floor level	Slab area (m <sup>2</sup> )	Table form (m <sup>2</sup> )	Compl. form-work (m <sup>2</sup> )	Rebar (kg)	Concrete volume (m <sup>3</sup> )	Prefabricated elements (pcs/floor)			Lift of materials (pcs/floor)	
								Stairs	Balc.	Col.	Infill	Other
1	1	1	316	260	56	1700	70	3	5	7	10	8
2	1	2	316	260	56	1700	70	3	5	7	10	8
3	1	3	316	260	56	1700	70	3	5	7	10	8
4	1	4	316	260	56	1700	70	3	5	7	10	8
5	1	5	316	260	56	1700	70	3	5	7	10	8
6	1	6	316	260	56	1700	70	3	5	7	10	8

**Table A.7.** Input items for costs and carbon emissions.

Concrete config.	Curing method	Time-dependent costs (EUR/day)			User-dependent cost				Carbon emissions			
		Wall form	Table forms	GSR	Curing methods (EUR/use)		Concrete (EUR/m <sup>3</sup> )		Concrete (kg/m <sup>3</sup> )		Curing methods (kg/use)	
					wall	slab	wall	slab	wall	slab	wall	slab
WS-STD	A	182	380	4463	1	4541	195	217	266	309	0	0
WS-10	A	182	380	4463	1	4541	192	212	241	280	0	0
WS-25	A	182	380	4463	1	4541	190	206	201	237	0	0
...	...	...	...	...	...	...	...	...	...	...	...	...
WS-STD	C	182	380	4463	23	5659	196	218	267	311	18	5355
WS-10	C	182	380	4463	23	5659	193	213	242	282	18	5355
WS-25	C	182	380	4463	23	5659	191	207	202	238	18	5355